

## GS26MFX Standard Compressor R134a 220-240V 50Hz

### General

Code number	107B0700
Approvals	EN 60335-2-34
Compressors on pallet	48

### Application

Application	MBP		
Frequency	Hz	50	60
Evaporating temperature	°C	-20 to 7.2	-
Voltage range	V	198 - 254	-
Max. condensing temperature continuous (short)	°C	60 (70)	-
Max. winding temperature continuous (short)	°C	125 (135)	-

### Cooling requirements

Frequency	Hz	50			60		
Application		LBP	MBP	HBP	LBP	MBP	HBP
32°C		-	F <sub>2</sub>	-	-	-	-
38°C		-	F <sub>2</sub>	-	-	-	-
43°C		-	F <sub>2</sub>	-	-	-	-
Remarks on application:							

### Motor

Motor type	CSR		
LRA (rated after 4 sec. UL984), HST   LST	A	20.2	-
Cut in Current, HST   LST	A	20.2	-
Resistance, main   start winding (25°C)	Ω	3.6	3.9

### Design

Displacement	cm <sup>3</sup>	26.30
Oil quantity (type)	cm <sup>3</sup>	900 (polyolester)
Maximum refrigerant charge	g	2000
Free gas volume in compressor	cm <sup>3</sup>	3350
Weight without electrical equipment	kg	19.1

### Dimensions

Height	mm	A	259
		B	247
		B1	234
		B2	234
Suction connector	location/I.D. mm   angle	C	12.9   90°
	material   comment		Copper   Rubber plug
Process connector	location/I.D. mm   angle	D	6.5   90°
	material   comment		Copper   Rubber plug
Discharge connector	location/I.D. mm   angle	E	8.2   19°
	material   comment		Copper   Rubber plug
Oil cooler connector	location/I.D. mm   angle	F	-
	material   comment		-
Connector tolerance	I.D. mm		12.9±0.15, 8.2 ±0.05, 6.5 ±0.10
Remarks:			

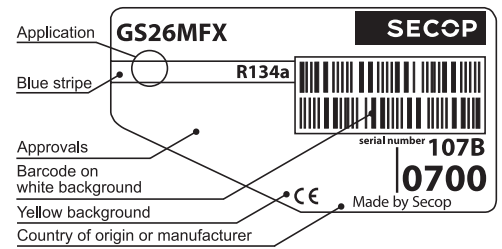

- S = Static cooling normally sufficient
- O = Oil cooling
- F<sub>1</sub> = Fan cooling 1.5 m/s (compressor compartment temperature equal to ambient temperature)
- F<sub>2</sub> = Fan cooling 3.0 m/s necessary
- SG = Suction gas cooling normally sufficient
- = not applicable in this area

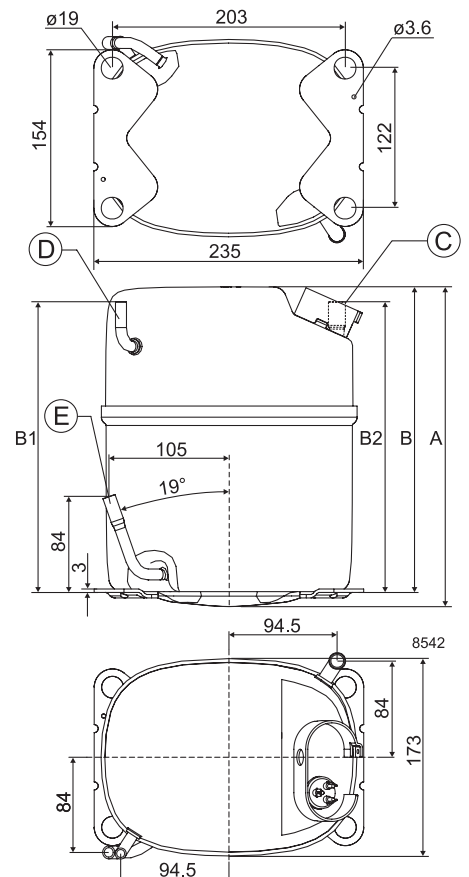

**EN 12900**

220V, 50Hz, fan cooling F<sub>2</sub>

Evap. temp. in °C	-45	-40	-35	-30	-25	-23.3	-20	-15	-10	-6.7	-5	0	5	7.2	10	15	20
Capacity in W							754	989	1266	1476	1591	1970	2411	2626			
Power cons. in W							546	618	696	745	776	857	942	980			
Current cons. in A							2.57	2.86	3.18	3.42	3.55	3.94	4.38	4.58			
COP in W/W							1.38	1.60	1.82	1.98	2.05	2.30	2.56	2.68			

**ARI 540-2004 (MBP)**

220V, 50Hz, fan cooling F<sub>2</sub>

Evap. temp. in °C	-45	-40	-35	-30	-25	-23.3	-20	-15	-10	-6.7	-5	0	5	7.2	10	15	20
Capacity in W							685	900	1153	1346	1451	1799					
Power cons. in W							552	629	710	766	794	883					
Current cons. in A							2.59	2.91	3.27	3.53	3.66	4.09					
COP in W/W							1.24	1.43	1.62	1.76	1.83	2.04					

**ARI 540-2004 (HBP)**

220V, 50Hz, fan cooling F<sub>2</sub>

Evap. temp. in °C	-45	-40	-35	-30	-25	-23.3	-20	-15	-10	-6.7	-5	0	5	7.2	10	15	20
Capacity in W							634	838	1076	1256	1353	1676	2052	2237			
Power cons. in W							562	645	733	794	826	924	1028	1077			
Current cons. in A							2.63	3.00	3.40	3.69	3.84	4.32	4.84	5.08			
COP in W/W							1.13	1.30	1.47	1.58	1.64	1.81	2.00	2.08			

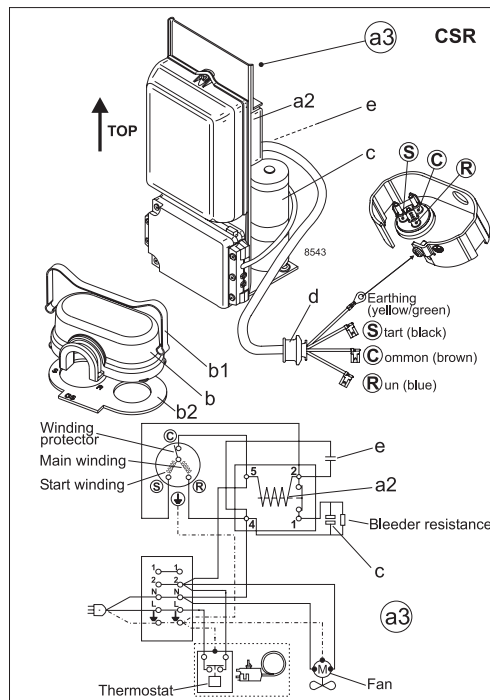

Accessories for GS26MFX	Figure	Code number	Test conditions	EN 12900	ARI 540-2004 (MBP)	ARI 540-2004 (HBP)
Starting device 600 mm cable length	a3	117-7055	Condensing temperature	45°C	48.9°C	54.4°C
			Ambient temperature	32°C	35°C	35°C
			Suction gas temperature	20°C	4.4°C	18.3°C
			Liquid temperature	no subcooling	no subcooling	no subcooling
Cover	b	107B9101 *)				
Clamp	b1	107B9104 *)				
Gasket	b2	107B9100 *)				
Starting relay	a2	Components of starting device	<b>Mounting accessories</b>			
Start. capacitor	c		Code number			
Run capacitor	e		107B9150			
*) Remarks: Cover, clamp, gasket parts of compressor			Bolt joint in quantities			
			Snap-on in quantities			

Secop accepts no responsibility for possible errors in catalogs, brochures, and other printed material. Secop reserves the right to alter its products without notice. This also applies to products already on order provided that such alterations can be made without consequential changes being necessary to specifications already agreed. All trademarks in this material are the property of the respective companies. Secop and the Secop logotype are trademarks of Secop GmbH. All rights reserved. [www.secop.com](http://www.secop.com)