



Kulthorn Group

HERMETIC

COMPRESSORS

CATALOGUE

WORLD CLASS PRODUCTS FOR REFRIGERATION & AIR CONDITIONING



KK Kulthorn Kirby
Public Company Limited

Company History

Kulthorn Kirby is the first hermetic compressor manufacturer in Thailand, established with Thailand Board of Investment promotion in 1980. The company was officially opened on January 13, 1982, with the initial production output of over 100,000 compressors in the first year of operation. Later, the production capacity was expanded to 5,000,000 units/year, of which more than 70% are exported worldwide. In 1991, the company was listed in the Stock Exchange of Thailand with 500 millions Baht registered capital.

Kulthorn Kirby is specialized in manufacturing of reciprocating compressor for refrigerators and air conditioners. We believe in our vision in producing the best quality - world standard products that best meet our customers' need and environmental friendly. Kulthorn Kirby Quality System is verified by Bureau Veritas Certification for : ISO 9001 : ISO 14001 :OHSAS 18001 and Kulthorn Kirby Compressor have received many international safety standard such as CE, CCC mark, UL and SASO.

NAME:	Kulthorn Kirby Public Company Limited
Company Registration No:	0107537002150 (Bor Mor Jor. 462)
Established:	24 March 1980
Grand Opening:	13 January 1982
Head Office & Factory:	44/1 and 61/1 Moo 7 Chalong Krung Road, Khwaeng Lam Pla thio, Khet Lat Krabang, Bangkok 10520, Thailand
Telephone:	(66) 2326 0831, 2739 4893
Fax:	(66) 2326 0837, 2739 4892
E-mail:	kkpc@loxinfo.co.th, kkc@kulthorn.com
Web site:	www.kulthorn.com
Employees:	1,900 persons
Land area:	65-3-2 rai (21 Acres)
Factory space:	85,300 sq.m.
Product:	Hermetic Motor Compressors for Refrigeration and Air-Conditioning Products
Brand name:	KULTHORN
Plant capacity:	4 million units/year of refrigeration compressors and 1 million units/year of air-conditioning compressors
Major Shareholders:	Simakulthorn Group Heatcraft Australia Pty Ltd. Thai Military Bank Plc. Original Equipment Manufacturers
Subsidiaries:	Kulthorn Kirby Foundry Co., Ltd. Kulthorn Premier Co., Ltd. Kulthorn Steel Co., Ltd.



Model Number System

Family Release Variant : A = 1 st., B = 2 nd., etc.

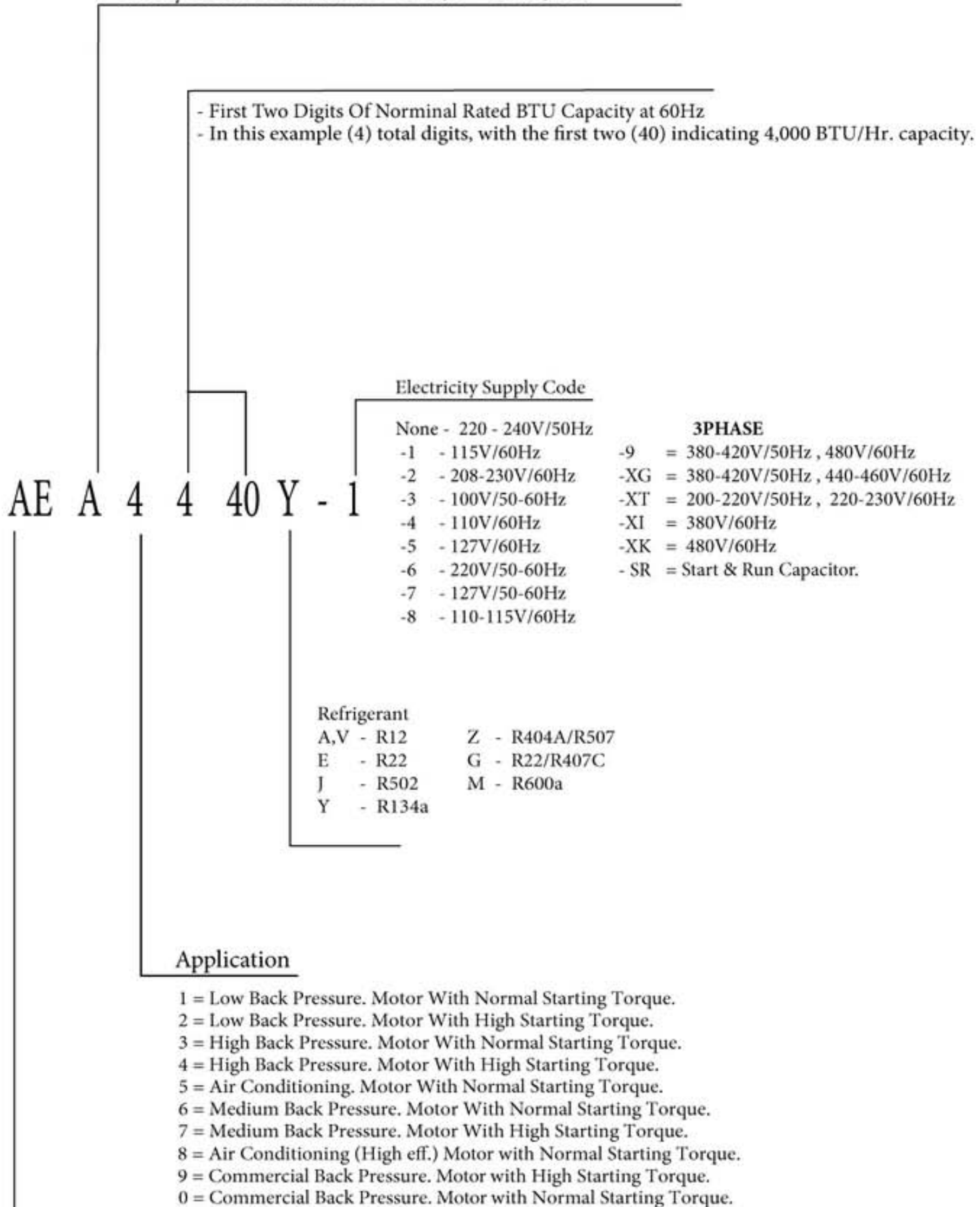

Compressor Family : AE-AZ-AZA-AW-WJ-BA-KA-LA

AZ Series

Model	Voltage	Hz.	App.	Motor Type	Disp. (CC)	Cooling (BTU/Hr)	Cooling (W)	Input (W)	COP W/W	RLA (A)	LRA (A)	Start CAP.		Run CAP.		Dim. "A"
												MFD	VAC.	MFD	VAC.	

AZ SERIES

R 134a
115 V/60 Hz. (LOW BACK PRESSURE)

AZ 1316Y-1	115	60	LBP	R.S.I.R.	2.23	154	45	62	0.73	1.10	11.30	No	No	No	No	162
AZ 1320Y-1	115	60	LBP	R.S.I.R.	2.95	242	71	76	0.93	1.11	10.80	No	No	No	No	162
AZ 1327Y-1	115	60	LBP	R.S.I.R.	3.28	287	84	88	0.95	1.34	15.90	No	No	No	No	168
AZ 1330Y-1	115	60	LBP	R.S.I.R.	3.59	297	87	93	0.94	1.33	12.00	No	No	No	No	168
AZ 1340Y-1	115	60	LBP	R.S.I.R.	5.00	450	132	123	1.07	1.89	20.00	No	No	No	No	172
AZ 1350Y-1	115	60	LBP	R.S.I.R.	5.59	505	148	143	1.03	2.11	18.00	No	No	No	No	178

220-240 V/50 Hz. (COMMERCIAL BACK PRESSURE)

AZ 0349Y	220-240	50	CBP	R.S.I.R.	2.95	512	150	110	1.36	0.74	7.00	No	No	No	No	162
AZ 0387Y	220-240	50	CBP	R.S.I.R.	4.00	734	215	144	1.49	0.98	9.60	No	No	No	No	172
AZ 0411Y	220-240	50	CBP	R.S.I.R.	5.59	955	280	189	1.48	1.17	10.50	No	No	No	No	178
AZ 9387Y	220-240	50	CBP	C.S.I.R.	4.00	734	215	144	1.49	0.98	9.60	36-43	330	No	No	172
AZ 9411Y	220-240	50	CBP	C.S.I.R.	5.59	955	280	189	1.48	1.17	10.50	36-43	330	No	No	178

115 V/60 Hz. (COMMERCIAL BACK PRESSURE)

AZ 0349Y-1	115	60	CBP	R.S.I.R.	2.95	601	176	125	1.41	1.51	15.00	No	No	No	No	168
AZ 0370Y-1	115	60	CBP	R.S.I.R.	3.28	652	191	140	1.36	1.86	17.10	No	No	No	No	168
AZ 0387Y-1	115	60	CBP	R.S.I.R.	4.00	850	249	174	1.43	2.37	22.00	No	No	No	No	172

208-230 V/60 Hz. (COMMERCIAL BACK PRESSURE)

AZ 0387Y-2	208-230	60	CBP	R.S.I.R.	4.00	846	248	178	1.39	1.33	14.30	No	No	No	No	172
------------	---------	----	-----	----------	------	-----	-----	-----	------	------	-------	----	----	----	----	-----

220 V/50-60 Hz. (COMMERCIAL BACK PRESSURE)

AZ 0370Y-6	220	50	CBP	R.S.I.R.	3.28	583	171	124	1.38	0.99	9.94	No	No	No	No	168
	220	60	CBP	R.S.I.R.	3.28	669	196	139	1.41	0.93	9.96	No	No	No	No	168
AZ 0411Y-6	220	50	CBP	R.S.I.R.	5.59	972	285	215	1.33	1.73	18.00	No	No	No	No	178
	220	60	CBP	R.S.I.R.	5.59	1,109	325	233	1.39	1.53	17.00	No	No	No	No	178
AZ 9411Y-6	220	50	CBP	C.S.I.R.	5.59	972	285	215	1.33	1.73	8.80	36-43	330	No	No	178
	220	60	CBP	C.S.I.R.	5.59	1,109	325	233	1.39	1.53	8.80	36-43	330	No	No	178

220-240 V/50 Hz. (HIGH BACK PRESSURE)

AZ 3414Y	220-240	50	HBP	R.S.I.R.	4.00	1,280	375	190	1.97	1.22	9.80	No	No	No	No	172
----------	---------	----	-----	----------	------	-------	-----	-----	------	------	------	----	----	----	----	-----

115 V/60 Hz. (HIGH BACK PRESSURE)

AZ 3414Y-1	115	60	HBP	R.S.I.R.	4.00	1,518	445	230	1.93	2.85	20.20	No	No	No	No	178
------------	-----	----	-----	----------	------	-------	-----	-----	------	------	-------	----	----	----	----	-----

208-230 V/60 Hz. (HIGH BACK PRESSURE)

AZ 3414Y-2	208-230	60	HBP	R.S.I.R.	4.00	1,518	445	235	1.89	1.60	12.20	No	No	No	No	172
------------	---------	----	-----	----------	------	-------	-----	-----	------	------	-------	----	----	----	----	-----

100 V/50-60 Hz. (HIGH BACK PRESSURE)

AZ 3414Y-3	100	50	HBP	R.S.I.R.	4.00	1,314	385	193	1.99	2.90	22.00	No	No	No	No	178
	100	60	HBP	R.S.I.R.	4.00	1,515	444	230	1.93	2.97	19.80	No	No	No	No	178
AZ 3414Y-3	100	50	HBP	R.S.C.R.	4.00	1,341	393	185	2.12	2.18	15.50	No	No	25	440	178
	100	60	HBP	R.S.C.R.	4.00	1,563	458	217	2.11	2.29	14.00	No	No	25	440	178

110 V/60 Hz. (HIGH BACK PRESSURE)

AZ 3414Y-4	110	60	HBP	R.S.I.R.	4.00	1,518	445	230	1.93	2.85	20.20	No	No	No	No	178
------------	-----	----	-----	----------	------	-------	-----	-----	------	------	-------	----	----	----	----	-----

AZ SERIES

R 404A/R 507
220-240 V/50 Hz. (LOW BACK PRESSURE)

AZ 2360Z	220-240	50	LBP	C.S.I.R.	3.59	540	158	150	1.06	1.00	6.20	36-43	330	No	No	178
AZ 2370Z	220-240	50	LBP	C.S.I.R.	4.00	631	185	166	1.10	1.00	6.20	36-43	330	No	No	178

RATING CONDITIONS (ASHRAE-T) FOR ALL SERIES AZ, AE, AW, AJ, AK, AV, AG

	LBP	MBP/CBP	HBP
- Evaporating Temp.	-10°F / -23°C	20°F / -7°C	45°F / 7°C
- Condensing Temp.	130°F / 54°C	130°F / 54°C	130°F / 54°C
- Return Gas Temp.	90°F / 32°C	95°F / 35°C	95°F / 35°C
- Liquid entering Temp.	90°F / 32°C	115°F / 46°C	115°F / 46°C
Expansion valve			
- Room Ambient	90°F / 32°C	95°F / 35°C	95°F / 35°C

AZA Series

Model	Voltage	Hz.	App.	Motor Type	Disp. (CC)	Cooling (BTU/Hr)	Cooling (W)	Input (W)	COP		RLA (A)	LRA (A)	Start CAP.		Run CAP.		Dim. "A"
									W/O Run	W/Run			MFD	VAC.	MFD	VAC.	
AZA SERIES													R 134 a				
220-240 V/50 Hz. (LOW BACK PRESSURE)																	
AZ A1320YK	220-240	50	LBP	R.S.I.R.	2.50	199	58	57	1.02	1.12	0.37	6.40	No	No	4	440	159
AZ A1327YK	220-240	50	LBP	R.S.I.R.	3.28	252	74	73	1.01	1.23	0.50	7.40	No	No	4	440	159
AZ A1330YK	220-240	50	LBP	R.S.I.R.	3.59	290	85	79	1.08	1.26	0.54	8.00	No	No	4	440	159
AZ A1335YK	220-240	50	LBP	R.S.I.R.	3.80	328	96	82	1.17	1.28	0.56	3.40	No	No	4	440	168
AZ A1340YK	220-240	50	LBP	R.S.I.R.	4.00	375	110	92	1.20	1.34	0.65	4.50	No	No	4	440	172
AZ A1350YK	220-240	50	LBP	R.S.I.R.	5.00	457	134	109	1.23	1.33	0.76	6.00	No	No	4	440	180
AZ A1360YK	220-240	50	LBP	R.S.I.R.	5.59	495	145	107	1.23	1.36	0.50	7.35	No	No	4	440	180
AZ A1370YK	220-240	50	LBP	R.S.I.R.	6.00	563	165	137	1.20	1.37	0.96	8.92	No	No	4	440	180
115 V/60 Hz. (LOW BACK PRESSURE)																	
AZ A1360YK-1	115	60	LBP	R.S.I.R.	5.59	631	185	155	1.19	-	2.72	26.00	No	No	No	No	178
AZ A2360YK-1	115	60	LBP	C.S.I.R.	5.59	631	185	155	1.19	-	2.72	18.00	108-130	250	No	No	178
208-230 V/60 Hz. (LOW BACK PRESSURE)																	
AZ A1327YK-2	208-230	60	LBP	R.S.I.R.	3.28	314	92	86	1.07	-	0.67	8.50	No	No	No	No	162
AZ A1330YK-2	208-230	60	LBP	R.S.I.R.	3.59	314	92	85	1.08	-	0.67	8.80	No	No	No	No	168
AZ A1335YK-2	208-230	60	LBP	R.S.I.R.	3.80	392	115	104	1.11	-	0.79	8.40	No	No	4	440	168
AZ A1340YK-2	208-230	60	LBP	R.S.I.R.	4.00	437	128	112	1.14	-	0.86	9.60	No	No	No	No	172
AZ A1360YK-2	208-230	60	LBP	R.S.I.R.	5.59	618	181	148	1.22	-	1.06	13.50	No	No	No	No	172
110 V/60 Hz. (LOW BACK PRESSURE)																	
AZ A1320YK-4	110	60	LBP	R.S.I.R.	2.86	273	80	79	1.01	-	1.20	11.00	No	No	No	No	168
AZ A1330YK-4	110	60	LBP	R.S.I.R.	3.59	314	92	85	1.08	-	1.21	12.50	No	No	No	No	168
AZ A1335YK-4	110	60	LBP	R.S.I.R.	3.80	392	115	104	1.11	-	1.75	15.60	No	No	No	No	168
AZ A1340YK-4	110	60	LBP	R.S.I.R.	4.00	437	128	112	1.14	-	1.65	15.00	No	No	No	No	172
AZ A1360YK-4	110	60	LBP	R.S.I.R.	5.59	614	180	155	1.16	-	2.72	26.00	No	No	No	No	178
AZ A2360YK-4	110	60	LBP	C.S.I.R.	5.59	631	185	155	1.19	-	2.72	18.00	108-130	250	No	No	178
127 V/60 Hz. (LOW BACK PRESSURE)																	
AZ A1335YK-5	127	60	LBP	R.S.I.R.	3.80	392	115	104	1.11	-	1.38	14.10	No	No	No	No	168
220-240 V/50 Hz. (COMMERCIAL BACK PRESSURE)																	
AZ A0413YK	220-240	50	CBP	R.S.I.R.	6.00	1,146	336	213	1.58	-	1.45	13.70	No	No	No	No	178
AZA9413Y	220-240	50	CBP	C.S.I.R.	6.00	1,160	340	213	1.60	-	1.60	8.70	36-43	330	No	No	178
115 V/60 Hz. (COMMERCIAL BACK PRESSURE)																	
AZ A0413YK-1	115	60	CBP	R.S.I.R.	6.00	1,361	399	255	1.56	-	3.17	28.80	No	No	No	No	178
AZ A9413Y-1	115	60	CBP	C.S.I.R.	6.00	1,310	384	260	1.48	-	3.60	19.60	36-43	250	No	No	178
208-230 V/60 Hz. (COMMERCIAL BACK PRESSURE)																	
AZ A0413YK-2	208-230	60	CBP	R.S.I.R.	6.00	1,331	390	265	1.47	-	1.80	17.60	No	No	No	No	178
AZ A9413YK-2	208-230	60	CBP	C.S.I.R.	6.00	1,366	400	265	1.51	-	2.00	12.00	36-43	330	No	No	178
100 V/50-60 Hz. (COMMERCIAL BACK PRESSURE)																	
AZ A0413YK-3	100	50	CBP	R.S.I.R.	6.00	1,143	335	240	1.40	-	4.25	26.40	No	No	No	No	178
	100	60	CBP	R.S.I.R.	6.00	1,331	390	266	1.52	-	3.69	24.20	No	No	No	No	178

AZ/AZA Compressor

General Dimensions (mm.)

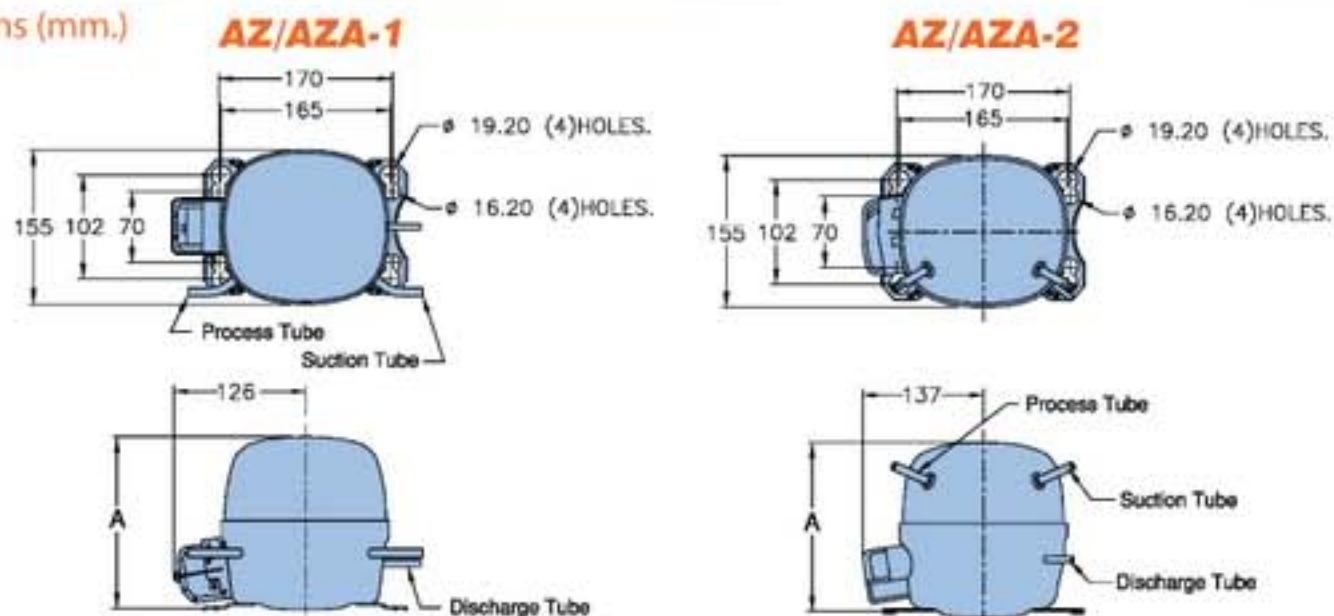

Allowed Positions For Shipping After Compressor Assembly

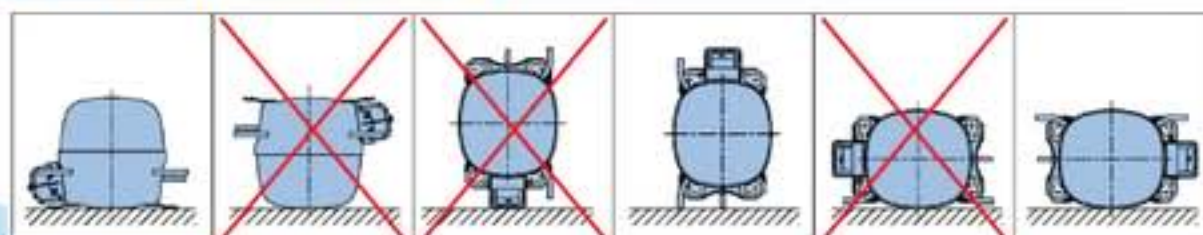

AE Series

Model	Voltage	Hz.	App.	Motor Type	Disp. (CC)	Cooling (BTU/Hr)	Cooling (W)	Input (W)	COP W/W	RLA (A)	LRA (A)	Start CAP.		Run CAP.		Dim. "A"
												MFD	VAC.	MFD	VAC.	
AE SERIES																
															R 134 a	
<i>220-240 V/50 Hz. (LOW BACK PRESSURE)</i>																
AE 1360Y	220-240	50	LBP	R.S.I.R.	6.91	539	158	140	1.13	1.00	10.00	No	No	No	No	189
	220-240	50	LBP	R.S.C.R.	6.91	570	167	127	1.31	0.58	4.20	No	No	4	440	189
AE 1370Y	220-240	50	LBP	R.S.I.R.	8.12	635	186	160	1.16	1.17	12.60	No	No	No	No	189
	220-240	50	LBP	R.S.C.R.	8.12	682	200	152	1.32	0.76	10.40	No	No	6	440	189
AE 1390Y	220-240	50	LBP	R.S.I.R.	9.42	860	252	192	1.31	1.28	14.10	No	No	No	No	202
	220-240	50	LBP	R.S.C.R.	9.42	904	265	192	1.38	0.87	10.30	No	No	4	440	189
AE 1411Y	220-240	50	LBP	R.S.I.R.	14.14	1,017	298	252	1.18	2.02	22.20	No	No	No	No	214
AE 2340Y	220-240	50	LBP	C.S.I.R.	5.11	375	110	107	1.03	0.77	5.80	36-43	330	No	No	189
AE 2360Y	220-240	50	LBP	C.S.I.R.	6.91	539	158	136	1.16	1.00	6.80	36-43	330	No	No	189
	220-240	50	LBP	C.S.R.	6.91	539	158	119	1.33	0.54	4.70	36-43	330	5	440	189
AE 2370Y	220-240	50	LBP	C.S.I.R.	8.12	631	185	163	1.13	1.18	6.50	36-43	330	No	No	189
	220-240	50	LBP	C.S.R.	8.12	631	185	143	1.29	0.70	6.80	36-43	330	5	440	189
AE 2390Y	220-240	50	LBP	C.S.I.R.	9.42	809	237	205	1.16	1.40	9.20	36-43	330	No	No	202
	220-240	50	LBP	C.S.R.	9.42	819	240	178	1.35	0.87	7.00	36-43	330	5	440	202
AEA 2410Y	220-240	50	LBP	C.S.I.R.	12.05	921	270	226	1.19	2.00	12.00	36-43	330	No	No	214
AEA 2413Y	220-240	50	LBP	C.S.I.R.	14.14	1,126	330	280	1.18	2.00	12.75	36-43	330	No	No	214
AEA 2415Y	220-240	50	LBP	C.S.R.	16.08	1,262	370	280	1.32	1.34	11.60	36-43	330	8	450	214
AE 2417Y	220-240	50	LBP	C.S.R.	18.00	1,365	400	325	1.23	1.70	16.00	36-43	330	10	440	214
<i>115 V/60 Hz. (LOW BACK PRESSURE)</i>																
AE 1350Y-1	115	60	LBP	R.S.I.R.	5.99	546	160	148	1.08	2.23	23.00	No	No	No	No	181
AE 1360Y-1	115	60	LBP	R.S.I.R.	6.91	645	189	170	1.11	2.35	21.80	No	No	No	No	189
<i>208-230 V/60 Hz. (LOW BACK PRESSURE)</i>																
AE 1360Y-2	208-230	60	LBP	R.S.I.R.	6.91	648	190	162	1.17	1.09	11.90	No	No	No	No	189
AE 1370Y-2	208-230	60	LBP	R.S.I.R.	8.12	717	210	184	1.14	1.27	16.70	No	No	No	No	189
AE 1390Y-2	208-230	60	LBP	R.S.I.R.	9.42	955	280	235	1.19	1.65	17.60	No	No	No	No	202
AE 2370Y-2	208-230	60	LBP	C.S.R.	8.12	751	220	170	1.29	0.80	7.80	36-43	330	5	440	189
AE 2390Y-2	208-230	60	LBP	C.S.I.R.	9.42	955	280	236	1.19	1.72	13.10	36-43	330	No	No	202
AE 2410Y-2	208-230	60	LBP	C.S.I.R.	14.14	1,065	312	307	1.02	2.50	15.90	36-43	330	No	No	214
AE 2413Y-2	208-230	60	LBP	C.S.R.	16.08	1,269	372	349	1.07	1.76	19.20	36-43	330	8	450	214
<i>100 V/50-60 Hz. (LOW BACK PRESSURE)</i>																
AE 2360Y-3	100	50	LBP	C.S.R.	6.91	597	175	155	1.13	1.97	16.90	36-43	250	15	440	189
	100	60	LBP	C.S.R.	6.91	682	200	183	1.09	1.90	14.80	36-43	250	15	440	189
AE 2370Y-3	100	50	LBP	C.S.R.	8.12	710	208	180	1.16	2.15	16.90	36-43	250	15	440	189
	100	60	LBP	C.S.R.	8.12	809	237	216	1.10	2.18	14.80	36-43	250	15	440	189
AE 2390Y-3	100	50	LBP	C.S.R.	9.42	819	240	196	1.22	2.70	27.06	108-130	250	15	440	189
	100	60	LBP	C.S.R.	9.42	955	280	230	1.22	2.45	23.30	108-130	250	15	440	189
<i>110 V/60 Hz. (LOW BACK PRESSURE)</i>																
AE 1327Y-4	110	60	LBP	R.S.I.R.	3.90	276	81	89	0.91	1.28	15.70	No	No	No	No	172
AE 1330Y-4	110	60	LBP	R.S.I.R.	4.08	317	93	95	0.98	1.60	16.00	No	No	No	No	172
AE 1340Y-4	110	60	LBP	R.S.I.R.	5.11	450	132	126	1.05	1.82	16.60	No	No	No	No	189
AE 2411Y-4	110	60	LBP	C.S.R.	14.14	1,109	325	275	1.18	2.83	28.00	108-130	250	15	440	214
<i>127 V/60 Hz. (LOW BACK PRESSURE)</i>																
AE 1350Y-5	127	60	LBP	R.S.I.R.	5.99	546	160	148	1.08	1.95	16.40	No	No	No	No	189
<i>220 V/50-60 Hz. (LOW BACK PRESSURE)</i>																
AE 1390Y-6	220	50	LBP	R.S.I.R.	9.42	870	255	203	1.26	1.55	16.50	No	No	No	No	202
	220	60	LBP	R.S.I.R.	9.42	1,013	297	236	1.26	1.50	15.00	No	No	No	No	202
<i>220-240 V/50 Hz. (COMMERCIAL BACK PRESSURE)</i>																
AE 0412Y	220-240	50	CBP	R.S.I.R.	5.99	1,075	315	201	1.57	1.48	14.00	No	No	No	No	189
	220-240	50	HBP	R.S.I.R.	5.99	1,955	573	259	2.21	1.67	14.00	No	No	No	No	189
AE 9437Y	220-240	50	CBP	C.S.R.	18.00	3,139	920	532	1.73	2.64	16.30	36-43	330	10	440	214
	220-240	50	HBP	C.S.R.	18.00	5,732	1,680	730	2.30	3.50	16.30	36-43	330	10	440	214
<i>110 V/60 Hz. (COMMERCIAL BACK PRESSURE)</i>																
AE 0412Y-4	110	60	CBP	R.S.I.R.	5.99	1,300	381	237	1.61	2.96	22.00	No	No	No	No	189
	110	60	HBP	R.S.I.R.	5.99	2,334	684	314	2.18	3.60	22.00	No	No	No	No	189
<i>208-230 V/60 Hz. (COMMERCIAL BACK PRESSURE)</i>																
AE 0412Y-2	208-230	60	CBP	R.S.I.R.	5.99	1,259	369	229	1.61	1.40	12.80	No	No	No	No	189
	208-230	60	HBP	R.S.I.R.	5.99	2,283	669	307	2.18	1.73	12.80	No	No	No	No	189
AE 9423Y-2	208-230	60	CBP	C.S.R.	12.05	2,327	682	396	1.72	1.85	13.00	36-43	330	8	450	202
	208-230	60	HBP	C.S.R.	12.05	4,333	1,270	560	2.27	2.60	13.00	36-43	330	8	450	202
AE 9437Y-2	208-230	60	CBP	C.S.R.	18.00	3,429	1,005	635	1.58	3.04	16.70	36-43	330	10	440	214
	208-230	60	HBP	C.S.R.	18.00	6,653	1,950	870	2.24	4.15	16.70	36-43	330	10	440	214

AE Series

Model	Voltage	Hz.	App.	Motor Type	Disp. (CC)	Cooling (BTU/Hr)	Cooling (W)	Input (W)	COP W/W	RLA (A)	LRA (A)	Start CAP.		Run CAP.		Dim. "A"
												MFD	VAC.	MFD	VAC.	
AE SERIES																
R 134 a																
<i>220-240 V/50 Hz. (MEDIUM BACK PRESSURE)</i>																
AE 6412Y	220-240	50	MBP	R.S.I.R.	5.99	1,061	311	193	1.61	1.22	11.60	No	No	No	No	189
AE 7415Y	220-240	50	MBP	C.S.I.R.	7.55	1,259	369	250	1.48	1.82	11.50	36-43	330	No	No	189
AE 7423Y	220-240	50	MBP	C.S.I.R.	12.05	1,958	574	361	1.59	2.28	18.50	36-43	330	No	No	202
AE 7426Y	220-240	50	MBP	C.S.I.R.	14.14	2,184	640	425	1.51	2.54	12.75	36-43	330	No	No	214
AE 7430Y	220-240	50	MBP	C.S.R.	16.08	2,542	745	455	1.64	2.18	12.75	36-43	330	8	450	214
<i>208-230 V/60 Hz. (MEDIUM BACK PRESSURE)</i>																
AE 7423Y-2	208-230	60	MBP	C.S.I.R.	12.05	2,286	670	438	1.53	12.60	2.70	36-43	330	No	No	202
AE 7425Y-2	208-230	60	MBP	C.S.I.R.	14.14	2,525	740	497	1.49	19.50	3.00	36-43	330	No	No	214
AE 7430Y-2	208-230	60	MBP	C.S.R.	16.08	2,955	866	530	1.63	2.56	17.00	36-43	330	8	450	214
<i>110 V/60 Hz. (MEDIUM BACK PRESSURE)</i>																
AE 7423Y-4	110	60	MBP	C.S.I.R.	12.05	2,286	670	435	1.54	5.10	24.60	120	250	No	No	202
<i>220-240 V/50 Hz. (HIGH BACK PRESSURE)</i>																
AE 3414Y	220-240	50	HBP	R.S.I.R.	4.49	1,262	370	223	1.66	1.30	8.30	No	No	No	No	172
AE 3417Y	220-240	50	HBP	R.S.I.R.	5.68	1,706	500	245	2.04	1.60	11.50	No	No	No	No	189
AE 3425Y	220-240	50	HBP	R.S.I.R.	7.55	2,491	730	342	2.13	2.20	13.60	No	No	No	No	189
AE 3430Y	220-240	50	HBP	R.S.I.R.	8.86	2,900	850	395	2.15	2.53	22.00	No	No	No	No	189
AE 3435Y	220-240	50	HBP	R.S.I.R.	9.42	3,044	892	427	2.09	2.65	21.10	No	No	No	No	189
AE 3440Y	220-240	50	HBP	R.S.I.R.	12.05	3,634	1,065	511	2.08	3.00	11.30	No	No	No	No	202
AE 3448Y	220-240	50	HBP	R.S.I.R.	14.14	4,094	1,200	595	2.02	3.50	29.10	No	No	No	No	214
AE 4414Y	220-240	50	HBP	C.S.I.R.	4.49	1,262	370	223	1.66	1.30	5.45	36-43	330	No	No	181
AE 4425Y	220-240	50	HBP	C.S.I.R.	7.55	2,388	700	327	2.14	2.15	10.70	36-43	330	No	No	189
AE 4430Y	220-240	50	HBP	C.S.I.R.	8.86	2,798	820	390	2.10	2.50	12.00	36-43	330	No	No	189
AE 4430Y	220-240	50	HBP	C.S.R.	8.86	2,716	796	339	2.35	1.60	9.50	36-43	330	8	450	189
AE 4435Y	220-240	50	HBP	C.S.I.R.	9.42	3,078	902	440	2.05	2.70	14.10	36-43	330	No	No	189
AE 4440Y	220-240	50	HBP	C.S.I.R.	12.05	3,668	1,075	505	2.13	3.10	14.70	36-43	330	No	No	202
AE 4440Y	220-240	50	HBP	C.S.R.	12.05	3,668	1,075	456	2.36	2.18	10.70	36-43	330	8	450	202
AE 4448Y	220-240	50	HBP	C.S.I.R.	14.14	4,060	1,190	575	2.07	3.45	23.90	36-43	330	No	No	214
AE 4448Y	220-240	50	HBP	C.S.R.	14.14	4,163	1,220	520	2.35	2.38	12.30	36-43	330	12	440	214
AE 4459Y	220-240	50	HBP	C.S.R.	16.08	4,947	1,450	660	2.20	3.00	15.70	36-43	330	15	440	214
<i>115 V/60 Hz. (HIGH BACK PRESSURE)</i>																
AE 3425Y-1	115	60	HBP	R.S.I.R.	7.55	2,736	802	401	2.00	4.30	22.60	No	No	No	No	189
AE 4425Y-1	115	60	HBP	C.S.I.R.	7.55	2,798	820	419	1.96	5.54	24.40	108-130	250	No	No	189
AE 4430Y-1	115	60	HBP	C.S.R.	8.86	3,293	965	432	2.23	3.90	23.00	108-130	250	30	440	189
AE 4440Y-1	115	60	HBP	C.S.R.	12.05	4,006	1,174	591	1.99	6.24	34.50	108-130	250	20	440	202
AE 4448Y-1	115	60	HBP	C.S.R.	14.14	4,968	1,456	682	2.13	6.70	41.50	108-130	250	20	440	214
<i>208-230 V/60 Hz. (HIGH BACK PRESSURE)</i>																
AE 3414Y-2	208-230	60	HBP	R.S.I.R.	4.49	1,570	460	253	1.82	1.66	15.50	No	No	No	No	181
AE 3417Y-2	208-230	60	HBP	R.S.I.R.	5.68	1,945	570	295	1.93	1.65	11.60	No	No	No	No	189
AE 3425Y-2	208-230	60	HBP	R.S.I.R.	7.57	2,764	810	392	2.07	2.30	12.50	No	No	No	No	189
AE 3430Y-2	208-230	60	HBP	R.S.I.R.	8.86	3,207	940	461	2.04	2.80	18.50	No	No	No	No	201
AE 4425Y-2	208-230	60	HBP	C.S.I.R.	7.55	2,753	807	390	2.07	2.26	12.60	36-43	330	No	No	189
AE 4430Y-2	208-230	60	HBP	C.S.I.R.	8.86	3,207	940	475	1.98	2.80	15.60	36-43	330	No	No	201
AE 4430Y-2	208-230	60	HBP	C.S.R.	8.86	3,320	973	436	2.23	2.00	14.90	36-43	330	8	450	189
AE 4440Y-2	208-230	60	HBP	C.S.I.R.	12.05	4,197	1,230	610	2.02	3.50	15.00	36-43	330	No	No	202
AE 4440Y-2	208-230	60	HBP	C.S.R.	12.05	4,333	1,270	560	2.27	2.60	13.00	36-43	330	8	450	202
AE 4448Y-2	208-230	60	HBP	C.S.R.	14.14	4,784	1,402	627	2.24	2.95	15.90	36-43	330	10	440	214
AE 4459Y-2	208-230	60	HBP	C.S.R.	16.08	5,613	1,645	774	2.13	3.57	18.00	36-43	330	15	440	214
<i>100 V/50-60 Hz. (HIGH BACK PRESSURE)</i>																
AE 4425Y-3	100	50	HBP	C.S.I.R.	7.57	2,395	702	356	1.97	5.80	25.80	108-130	250	No	No	189
AE 4425Y-3	100	60	HBP	C.S.I.R.	7.57	2,832	830	393	2.11	5.16	24.00	108-130	250	No	No	189
AE 4430Y-3	100	50	HBP	C.S.I.R.	8.86	2,798	820	412	1.99	6.00	25.80	108-130	250	No	No	189
AE 4430Y-3	100	60	HBP	C.S.I.R.	8.86	3,207	940	475	1.98	5.90	24.00	108-130	250	No	No	189
AE 4440Y-3	100	50	HBP	C.S.I.R.	12.05	3,670	1,075	560	1.92	8.00	37.00	130-156	330	No	No	202
AE 4440Y-3	100	60	HBP	C.S.I.R.	12.05	4,250	1,245	620	2.01	7.70	37.00	130-156	330	No	No	202
AE 4448Y-3	100	50	HBP	C.S.R.	14.14	4,367	1,280	570	2.25	6.35	24.10	130-156	330	35	440	214
AE 4448Y-3	100	60	HBP	C.S.R.	14.14	4,879	1,430	695	2.06	6.98	23.00	130-156	330	35	440	214

AE Series

Model	Voltage	Hz.	App.	Motor Type	Disp. (CC)	Cooling (BTU/Hr)	Cooling (W)	Input (W)	COP W/W	RLA (A)	LRA (A)	Start CAP.		Run CAP.		Dim. "A"
												MFD	VAC.	MFD	VAC.	
AE SERIES												R 134 a				
<i>110 V/60 Hz. (HIGH BACK PRESSURE)</i>																
AE 3414Y-4	110	60	HBP	R.S.I.R.	4.49	1,597	468	246	1.90	2.77	16.80	No	No	No	No	172
AE 4425Y-4	110	60	HBP	C.S.I.R.	7.55	2,791	818	410	2.00	5.32	24.40	108-130	250	No	No	189
AE 4430Y-4	110	60	HBP	C.S.I.R.	8.86	3,272	959	490	1.96	5.88	29.90	108-130	250	No	No	189
	110	60	HBP	C.S.R.	8.86	3,293	965	432	2.23	3.90	23.00	108-130	250	30	440	189
AE 4440Y-4	110	60	HBP	C.S.R.	12.05	4,333	1,270	560	2.27	5.12	14.00	108-130	250	30	440	202
AE 4448Y-4	110	60	HBP	C.S.R.	14.14	4,947	1,450	652	2.22	6.52	32.20	108-130	250	20	440	214
<i>220 V/50-60 Hz. (HIGH BACK PRESSURE)</i>																
AE 3425Y-6	220	50	HBP	R.S.I.R.	7.57	2,423	710	343	2.07	2.53	17.50	No	No	No	No	189
	220	60	HBP	R.S.I.R.	7.57	2,849	835	396	2.11	2.36	16.70	No	No	No	No	189
AE 4430Y-6	220	50	HBP	C.S.R.	8.86	2,716	796	339	2.35	1.60	9.50	36-43	330	8	450	189
	220	60	HBP	C.S.R.	8.86	3,276	960	416	2.31	1.90	10.00	36-43	330	8	450	189
AE 4440Y-6	220	50	HBP	C.S.R.	12.05	3,668	1,075	456	2.36	2.18	10.70	36-43	330	8	450	202
	220	60	HBP	C.S.R.	12.05	4,357	1,277	550	2.32	2.53	11.15	36-43	330	8	450	202
AE SERIES												R 22				
<i>220-240 V/50 Hz. (COMMERCIAL BACK PRESSURE)</i>																
AE 9422EK	220-240	50	MBP	C.S.I.R.	7.57	2,030	595	417	1.43	2.30	14.80	36-43	330	No	No	189
<i>220-240 V/50 Hz. (MEDIUM BACK PRESSURE)</i>																
AE 6412EK	220-240	50	MBP	R.S.I.R.	4.49	989	290	240	1.21	1.40	11.40	No	No	No	No	189
AE 7415EK	220-240	50	MBP	C.S.I.R.	5.48	1,262	370	310	1.19	2.10	11.50	36-43	250	No	No	189
AE 7422EK	220-240	50	MBP	C.S.I.R.	7.55	1,877	550	420	1.31	2.40	11.50	36-43	330	No	No	189
AE 7426EK	220-240	50	MBP	C.S.I.R.	8.85	2,184	640	480	1.33	2.70	12.75	36-43	330	No	No	201
AE 7435EK	220-240	50	MBP	C.S.R.	12.04	2,968	870	550	1.58	2.50	12.75	36-43	330	8	440	214
AE 7440EK	220-240	50	MBP	C.S.R.	14.14	3,446	1,010	660	1.53	3.00	12.75	36-43	330	12	440	214
AE 7445EK	220-240	50	MBP	C.S.R.	16.08	3,798	1,113	801	1.39	3.70	16.00	36-43	330	15	440	214
<i>208-230 V/60 Hz. (MEDIUM BACK PRESSURE)</i>																
AE 7415EK-2	208-230	60	MBP	C.S.I.R.	5.48	1,467	430	360	1.19	2.40	12.70	36-43	330	No	No	189
AE 7422EK-2	208-230	60	MBP	C.S.I.R.	7.57	2,238	656	490	1.34	2.90	15.60	36-43	330	No	No	189
AE 7426EK-2	208-230	60	MBP	C.S.I.R.	8.85	2,678	785	577	1.36	3.30	16.40	36-43	330	No	No	201
AE 7435EK-2	208-230	60	MBP	C.S.R.	12.04	3,361	985	689	1.43	3.30	16.10	36-43	330	8	450	214
AE 7440EK-2	208-230	60	MBP	C.S.R.	14.14	4,002	1,173	793	1.48	3.64	17.06	36-43	330	15	440	214
<i>110 V/60 Hz. (MEDIUM BACK PRESSURE)</i>																
AE 6412EK-4	110	60	MBP	R.S.I.R.	4.49	1,280	375	300	1.25	3.68	23.00	No	No	No	No	189
AE 7415EK-4	110	60	MBP	C.S.I.R.	5.48	1,484	435	408	1.07	5.10	32.60	108-130	250	No	No	189
AE 7422EK-4	110	60	MBP	C.S.I.R.	7.55	2,228	653	502	1.30	6.10	30.00	108-130	250	No	No	189
	110	60	MBP	C.S.R.	7.55	2,252	660	475	1.39	5.24	26.20	108-130	250	10	440	189
AE 7426EK-4	110	60	MBP	C.S.R.	8.85	2,784	816	550	1.48	5.29	32.00	108-130	250	20	440	201
<i>220-240 V/50 Hz. (HIGH BACK PRESSURE)</i>																
AE 3422EK	220-240	50	HBP	R.S.I.R.	4.49	1,887	553	321	1.72	2.21	9.40	No	No	No	No	189
AE 4422EK	220-240	50	HBP	C.S.I.R.	4.49	1,924	564	357	1.58	2.21	9.40	36-43	330	No	No	189
AE 4430EK	220-240	50	HBP	C.S.R.	6.92	2,907	852	467	1.82	2.30	14.90	36-43	330	8	450	202
AE 4440EK	220-240	50	HBP	C.S.R.	7.57	3,412	1,000	453	2.21	2.20	13.00	36-43	330	8	450	214
AE 4448EK	220-240	50	HBP	C.S.R.	8.85	3,999	1,172	560	2.09	2.70	12.75	36-43	330	8	450	202
AE 4474EK	220-240	50	HBP	C.S.R.	14.14	6,142	1,800	840	2.14	3.95	19.20	36-43	330	15	440	214
AE 5448EK	220-240	50	HBP	C.S.R.	8.85	3,999	1,172	560	2.09	2.70	12.75	36-43	330	8	450	202
<i>208-230 V/60 Hz. (HIGH BACK PRESSURE)</i>																
AE 4430EK-2	208-230	60	HBP	C.S.R.	6.92	3,207	940	585	1.61	2.85	15.90	36-43	330	8	450	202
AE 4440EK-2	208-230	60	HBP	C.S.R.	7.55	4,094	1,200	568	2.11	2.80	16.70	36-43	330	8	450	202
AE 4448EK-2	208-230	60	HBP	C.S.R.	8.86	4,606	1,350	725	1.86	3.50	15.80	36-43	330	8	450	202
AE 4474EK-2	208-230	60	HBP	C.S.R.	14.14	7,387	2,165	1,070	2.02	5.10	21.20	36-43	330	15	440	214
AE 5462EK-2	208-230	60	HBP	P.S.C.	14.14	7,387	2,165	1,070	2.02	5.10	21.20	No	No	15	440	214
<i>110 V/60 Hz. (HIGH BACK PRESSURE)</i>																
AE 3422EK-4	110	60	HBP	R.S.I.R.	4.49	2,201	645	400	1.61	5.00	30.80	No	No	No	No	189
AE 4430EK-4	110	60	HBP	C.S.R.	6.92	3,276	960	600	1.60	5.52	33.00	108-130	250	20	440	202
AE 4440EK-4	110	60	HBP	C.S.R.	7.55	4,248	1,245	595	2.09	6.35	34.00	108-130	250	15	440	202
AE 4448EK-4	110	60	HBP	C.S.R.	8.85	4,999	1,465	727	2.02	6.96	37.00	108-130	250	20	440	202

AE Series

Model	Voltage	Hz.	App.	Motor Type	Disp. (CC)	Cooling (BTU/Hr)	Cooling (W)	Input (W)	COP W/W	RLA (A)	LRA (A)	Start CAP.		Run CAP.		Dim. "A"
												MFD	VAC.	MFD	VAC.	

AE SERIES

R 404A/R 507

220-240 V/50 Hz. (LOW BACK PRESSURE)

AE 2410ZK	220-240	50	LBP	C.S.I.R.	5.99	921	270	239	1.13	1.53	9.20	36-43	330	No	No	189
	220-240	50	LBP	C.S.R.	5.99	969	284	213	1.33	1.04	11.20	36-43	330	5	440	189
AE 2413ZK	220-240	50	LBP	C.S.I.R.	6.91	1,109	325	284	1.14	2.00	11.10	36-43	330	No	No	189
AE 2416ZK	220-240	50	LBP	C.S.I.R.	8.86	1,399	410	352	1.16	2.31	13.20	36-43	330	No	No	202
	220-240	50	LBP	C.S.R.	8.86	1,399	410	303	1.35	1.40	12.00	36-43	330	8	440	189
AE 2420ZK	220-240	50	LBP	C.S.R.	12.05	1,699	498	370	1.35	1.78	10.70	36-43	330	8	440	202
AE 2425ZK	220-240	50	LBP	C.S.R.	14.14	2,092	613	488	1.26	2.71	16.30	36-43	330	8	450	214
AE 2428ZK	220-240	50	LBP	C.S.R.	16.08	2,388	700	560	1.25	2.88	15.70	36-43	330	8	450	214
AE 2432ZK	220-240	50	LBP	C.S.R.	18.00	2,640	774	660	1.17	3.30	21.00	36-43	330	15	440	214

208-230 V/60 Hz. (LOW BACK PRESSURE)

AE 2410ZK-2	208-230	60	LBP	C.S.I.R.	5.99	1,153	338	278	1.22	1.85	13.56	36-43	330	No	No	189
	208-230	60	LBP	C.S.R.	5.99	1,153	338	262	1.29	1.34	12.40	36-43	330	4	440	189
AE 2413ZK-2	208-230	60	LBP	C.S.I.R.	6.91	1,307	383	323	1.19	1.20	12.00	36-43	330	No	No	189
	208-230	60	LBP	C.S.R.	6.91	1,331	390	300	1.30	1.50	12.20	36-43	330	4	440	189
AE 2416ZK-2	208-230	60	LBP	C.S.R.	8.12	1,580	463	348	1.33	1.72	15.50	36-43	330	5	440	189
AE 2420ZK-2	208-230	60	LBP	C.S.R.	12.05	1,962	575	475	1.21	2.18	16.90	36-43	330	10	440	214
AE 2425ZK-2	208-230	60	LBP	C.S.R.	14.14	2,286	670	546	1.23	2.61	27.14	36-43	330	12	440	214
AE 2428ZK-2	208-230	60	LBP	C.S.R.	16.08	2,730	800	656	1.22	3.20	20.30	36-43	330	12	440	214

100 V/50-60 Hz. (LOW BACK PRESSURE)

AE 2410ZK-3	100	50	LBP	C.S.I.R.	5.99	969	284	280	1.01	5.03	27.00	108-130	250	No	No	189
	100	60	LBP	C.S.I.R.	5.99	1,136	333	295	1.13	4.24	23.00	108-130	250	No	No	189
AE 2413ZK-3	100	50	LBP	C.S.I.R.	6.91	1,109	325	358	0.91	6.10	27.00	108-130	250	No	No	189
	100	60	LBP	C.S.I.R.	6.91	1,314	385	360	1.07	5.00	23.60	108-130	250	No	No	189

AE SERIES

R 407C

220-240 V/50 Hz. (MEDIUM BACK PRESSURE)

AE 7445GK	220-240	50	MBP	C.S.R.	16.08	3,798	1,113	801	1.39	4.00	16.00	36-43	330	15	440	214
AE 7457GK	220-240	50	MBP	C.S.R.	18.00	4,367	1,280	880	1.45	4.26	21.10	36-43	330	15	440	214

220-240 V/60 Hz. (HIGH BACK PRESSURE)

AE 5462GK	220-240	50	HBP	P.S.C.	14.14	5,906	1,731	804	2.15	3.77	18.00	No	No	15	440	214
-----------	---------	----	-----	--------	-------	-------	-------	-----	------	------	-------	----	----	----	-----	-----

208-230 V/60 Hz. (HIGH BACK PRESSURE)

AE 5462GK-2	208-230	60	HBP	P.S.C.	14.14	7,097	2,080	970	2.14	4.50	24.00	No	No	15	440	214
-------------	---------	----	-----	--------	-------	-------	-------	-----	------	------	-------	----	----	----	-----	-----

AE Compressor

General Dimensions (mm.)

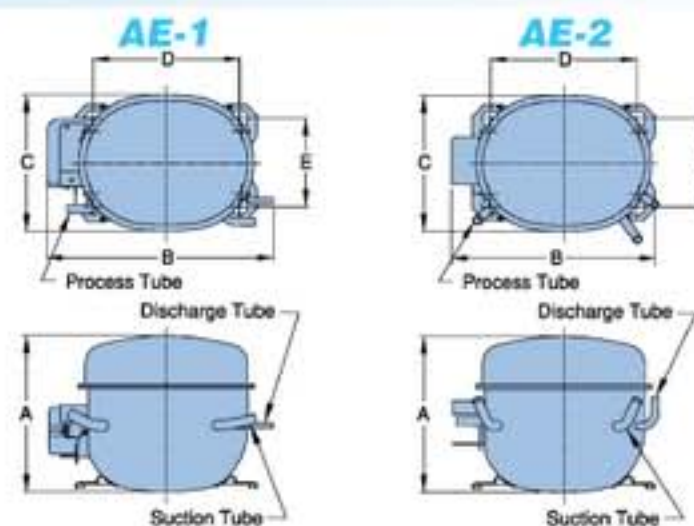

Allowed Positions For Shipping After Compressor Assembly

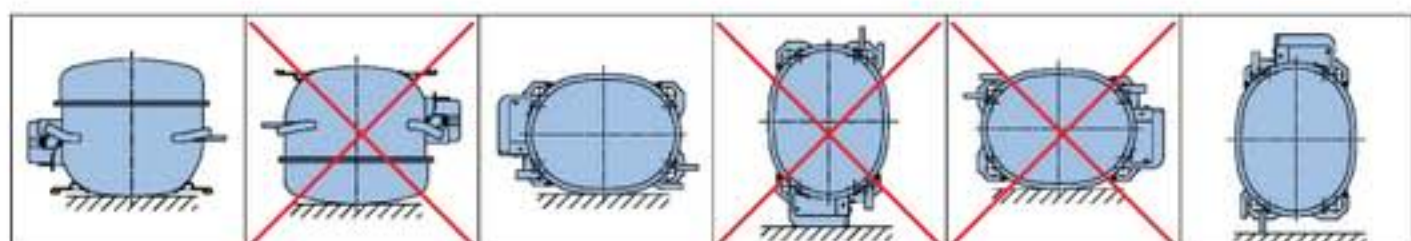

BA Series

Model	Voltage	Hz.	App.	Motor Type	Disp. (CC)	Cooling (BTU/Hr)	Cooling (W)	Input (W)	COP W/W	RLA (A)	LRA (A)	Start CAP.		Run CAP.		Dim. "A"
												MFD	VAC.	MFD	VAC.	

BA SERIES **R 134 a**

220-240 V/50 Hz. (LOW BACK PRESSURE)

BA 1360Y	220-240	50	LBP	R.S.I.R.	5.99	546	160	120	1.33	0.90	10.00	No	No	No	No	193
	220-240	50	LBP	R.S.C.R.	5.99	546	160	110	1.45	0.90	10.00	No	No	4	440	193
BA1370Y	220-240	50	LBP	R.S.I.R.	6.91	672	197	147	1.34	1.10	12.00	No	No	No	No	193
	220-240	50	LBP	R.S.C.R.	6.91	679	199	138	1.44	1.10	12.00	No	No	4	440	193
BA 1390Y	220-240	50	LBP	R.S.I.R.	8.11	819	240	174	1.38	1.20	12.00	No	No	No	No	193
	220-240	50	LBP	R.S.C.R.	8.11	826	242	163	1.48	1.20	12.00	No	No	4	440	193
BA 1410Y	220-240	50	LBP	R.S.I.R.	9.42	945	277	208	1.33	1.60	20.00	No	No	No	No	205
	220-240	50	LBP	R.S.C.R.	9.42	938	275	190	1.45	1.60	20.00	No	No	4	440	205
BA 2413Y	220-240	50	LBP	C.S.I.R.	10.90	1,110	325	253	1.28	1.76	10.00	36-43	330	No	No	193

BA SERIES **R 404A/R 507**

220-240 V/50 Hz. (MEDIUM BACK PRESSURE)

BA 7430Z	220-240	50	MBP	C.S.R.	8.85	2,577	755	495	1.53	2.50	17.00	36-43	330	8	440	205
BA 7440Z	220-240	50	MBP	C.S.R.	12.05	3,300	967	616	1.57	1.98	18.00	36-43	330	15	440	215
BA 7443Z	220-240	50	MBP	C.S.R.	14.14	3,900	1,143	770	1.48	3.70	18.60	36-43	330	20	440	215
BA 7452Z	220-240	50	MBP	C.S.R.	16.08	4,500	1,319	895	1.47	4.60	25.00	36-43	330	15	440	215
BA 7459Z	220-240	50	MBP	C.S.R.	18.00	4,947	1,450	1,030	1.41	5.00	25.10	36-43	330	20	440	215

208-230 V/60 Hz. (MEDIUM BACK PRESSURE)

BA 7440Z-2	208-230	60	MBP	C.S.R.	12.05	3,850	1,128	732	1.54	3.70	29.00	36-43	330	12	440	215
BA 7443Z-2	208-230	60	MBP	C.S.R.	14.14	4,290	1,257	880	1.43	4.40	27.30	36-43	330	15	440	215

BA Compressor

General Dimensions (mm.)

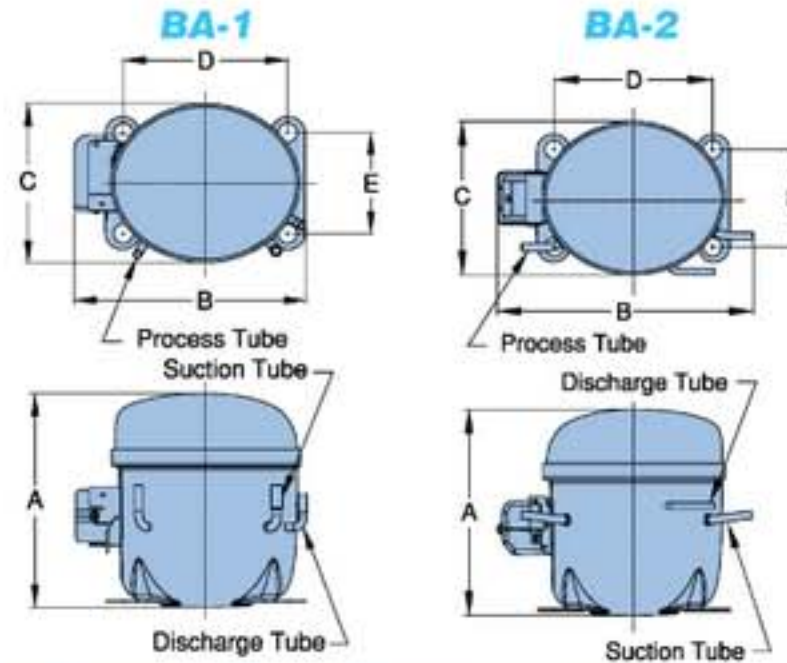

Allowed Positions For Shipping After Compressor Assembly

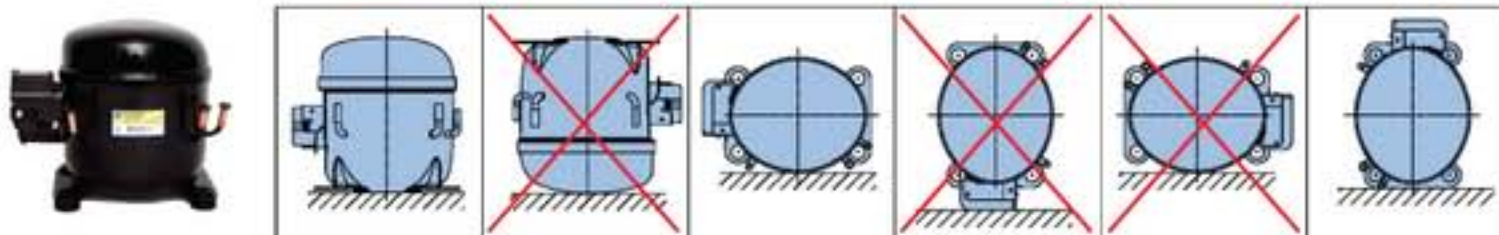

WJ Series

Model	Voltage	Hz.	App.	Motor Type	Disp. (CC)	Cooling (BTU/Hr)	Input (W)	EER	RLA (A)	LRA (A)	Start CAP.		Run CAP.		Dim. "A"
											MFD	VAC.	MFD	VAC.	
WJ SERIES											R 134 a				
<i>220-240 V/50 Hz. (COMMERCIAL BACK PRESSURE)</i>															
WJ 9430YK	220-240	50	CBP	C.S.R.	19.80	3,000	490	6.12	2.10	19.00	88-106	330	15	440	264
WJ 9440YK	220-240	50	CBP	C.S.R.	21.55	3,490	560	6.23	2.60	19.00	88-106	330	15	440	264
WJ 9445YK	220-240	50	CBP	C.S.R.	24.20	3,990	640	6.23	2.90	18.70	88-106	330	20	440	264
WJ 9450YK	220-240	50	CBP	C.S.R.	26.75	4,590	790	5.81	4.80	30.00	88-106	330	15	440	264
WJ 9460YK	220-240	50	CBP	C.S.R.	30.50	5,390	870	6.20	4.20	30.00	88-106	330	15	440	264
<i>115 V/60 Hz. (COMMERCIAL BACK PRESSURE)</i>															
WJ 9440YK-1	115	60	CBP	C.S.R.	21.55	4,020	685	5.87	6.50	46.80	216-259	250	25	440	264
WJ 9445YK-1	115	60	CBP	C.S.R.	24.20	4,700	810	5.80	7.60	52.00	216-259	250	30	440	264
WJ 9460YK-1	115	60	CBP	C.S.R.	30.50	6,250	1,090	5.73	9.74	61.00	216-259	250	30	440	264
<i>208-230 V/60 Hz. (COMMERCIAL BACK PRESSURE)</i>															
WJ 9440YK-2	208-230	60	CBP	C.S.R.	21.55	3,950	680	5.81	3.16	19.40	88-106	330	20	440	264
WJ 9445YK-2	208-230	60	CBP	C.S.R.	24.20	4,660	767	6.08	3.54	37.00	108-130	330	20	440	264
WJ 9460YK-2	208-230	60	CBP	C.S.R.	30.50	6,140	1,025	5.99	4.70	32.00	108-130	330	15	440	264

WJ SERIES											R 22				
<i>220-240 V/50 Hz. (COMMERCIAL BACK PRESSURE)</i>															
WJ 9460EK	220-240	50	CBP	C.S.R.	19.80	5,080	855	5.94	4.60	28.00	88-106	330	15	440	264
WJ 9470EK	220-240	50	CBP	C.S.R.	21.55	5,800	958	6.05	4.55	30.00	88-106	330	20	440	264
WJ 9480EK	220-240	50	CBP	C.S.R.	24.20	6,480	1,100	5.89	5.30	28.00	88-106	330	25	440	264
WJ 9485EK	220-240	50	CBP	C.S.R.	26.70	7,300	1,246	5.86	5.66	38.00	145-174	330	25	440	264
WJ 9510EK	220-240	50	CBP	C.S.R.	30.50	8,390	1,425	5.89	6.47	40.00	145-174	330	25	440	264
<i>220-240 V/50 Hz. (HIGH BACK PRESSURE)</i>															
WJ 4518EK	220-240	50	HBP	C.S.R.	30.50	15,090	1,780	8.48	8.60	43.00	88-106	330	25	440	264
WJ 5510EK	220-240	50	HBP	P.S.C.	19.80	9,170	1,094	8.38	5.50	28.00	No	No	15	440	264
WJ 5513EK	220-240	50	HBP	P.S.C.	21.50	10,790	1,218	8.86	5.56	30.00	No	No	20	440	264
WJ 5515EK	220-240	50	HBP	P.S.C.	24.20	12,000	1,360	8.82	6.40	28.00	No	No	25	440	264
WJ 5516EK	220-240	50	HBP	P.S.C.	26.75	13,390	1,550	8.64	6.88	38.00	No	No	25	440	264
WJ 5518EK	220-240	50	HBP	P.S.C.	30.50	15,090	1,780	8.48	8.60	43.00	No	No	25	440	264
<i>208-230 V/60 Hz. (HIGH BACK PRESSURE)</i>															
WJ 5510EK-2	208-230	60	HBP	P.S.C.	19.80	11,560	1,380	8.38	7.07	37.30	No	No	15	440	264
WJ 5513EK-2	208-230	60	HBP	P.S.C.	21.50	13,000	1,485	8.75	6.54	32.00	No	No	25	440	264
WJ 5515EK-2	208-230	60	HBP	P.S.C.	24.20	14,390	1,717	8.38	8.10	38.10	No	No	25	440	264
WJ 5516EK-2	208-230	60	HBP	P.S.C.	26.75	16,100	1,925	8.36	8.75	43.90	No	No	25	440	264
WJ 5518EK-2	208-230	60	HBP	P.S.C.	30.50	18,690	2,230	8.38	10.00	53.00	No	No	30	440	264

WJ SERIES											R 407C				
<i>220-240 V/50 Hz. (COMMERCIAL BACK PRESSURE)</i>															
WJ 9460GK	220-240	50	CBP	C.S.R.	19.80	5,080	855	5.94	4.60	28.00	88-106	330	15	440	264
WJ 9470GK	220-240	50	CBP	C.S.R.	21.55	5,800	958	6.05	4.55	30.00	88-106	330	20	440	264
WJ 9480GK	220-240	50	CBP	C.S.R.	24.20	6,480	1,100	5.89	5.30	28.00	88-106	330	25	440	264
WJ 9485GK	220-240	50	CBP	C.S.R.	26.70	7,300	1,246	5.86	5.66	38.00	145-175	330	25	440	264
WJ 9510GK	220-240	50	CBP	C.S.R.	30.50	8,390	1,425	5.89	6.47	40.00	145-174	330	25	440	264

WJ SERIES											R 404A				
<i>220-240 V/50 Hz. (LOW BACK PRESSURE)</i>															
WJ 2430ZK	220-240	50	LBP	C.S.R.	19.80	2,390	550	4.35	2.55	30.00	108-130	330	20	440	264
WJ 2435ZK	220-240	50	LBP	C.S.R.	21.50	2,900	637	4.55	2.70	30.00	108-130	330	20	440	264
WJ 2440ZK	220-240	50	LBP	C.S.R.	24.20	3,290	731	4.50	3.32	30.00	145-174	330	25	440	264
WJ 2450ZK	220-240	50	LBP	C.S.R.	26.75	3,800	865	4.39	4.53	34.00	145-174	330	25	440	264
WJ 2455ZK	220-240	50	LBP	C.S.R.	30.50	4,700	1,050	4.48	4.90	35.00	145-174	330	25	440	264
<i>220-240 V/50 Hz. (COMMERCIAL BACK PRESSURE)</i>															
WJ 9470Z	220-240	50	MBP	C.S.R.	21.50	6,176	1,050	5.88	4.90	23.20	88-106	330	25	425	264
	220-240	50	HBP	C.S.R.	21.50	10,850	1,358	7.99	6.40	23.20	88-106	330	25	425	264
WJ 9485Z	220-240	50	MBP	C.S.R.	24.20	7,438	1,260	5.90	6.20	31.00	88-106	330	25	425	264
	220-240	50	HBP	C.S.R.	24.20	12,930	1,630	7.93	7.80	31.00	88-106	330	25	425	264
WJ 9490Z	220-240	50	MBP	C.S.R.	26.70	8,000	1,400	5.72	7.00	33.00	108-130	330	20	440	264
	220-240	50	HBP	C.S.R.	26.70	13,600	1,833	7.42	9.00	33.00	108-130	330	20	440	264
WJ 9510Z	220-240	50	MBP	C.S.R.	30.50	9,200	1,690	5.44	9.00	47.00	108-130	330	25	425	264
	220-240	50	HBP	C.S.R.	30.50	16,000	2,130	7.51	11.00	47.00	108-130	330	25	425	264

AW Series

Model	Voltage	Hz.	App.	Motor Type	Disp. (CC)	Cooling (BTU/Hr)	Input (W)	EER	RLA (A)	LRA (A)	Start CAP.		Run CAP.		Dim. "A"
											MFD	VAC.	MFD	VAC.	

AW SERIES

R 134 a

220-240 V/50 Hz. (MEDIUM BACK PRESSURE)

AW 4495YK	220-240	50	MBP	C.S.R.	30.50	3,580	680	5.26	3.50	33.00	88-106	330	20	370/440	289
AW 4513YK	220-240	50	MBP	C.S.R.	35.60	4,570	742	6.16	3.94	50.48	88-106	330	30	370/440	289
AW 4514YK	220-240	50	MBP	C.S.R.	37.50	4,770	745	6.40	3.94	54.10	88-106	330	35	370/440	324
AW 4515YK	220-240	50	MBP	C.S.R.	39.60	5,350	847	6.32	4.16	54.10	88-106	330	35	370/440	324
AW 4517YK	220-240	50	MBP	C.S.R.	48.40	7,330	1,050	6.98	4.90	35.00	108-130	330	20	370/440	324

220-240 V/50 Hz. (HIGH BACK PRESSURE)

AW 4495YK	220-240	50	HBP	C.S.R.	30.50	8,120	851	9.54	4.36	33.00	88-106	330	20	370/440	289
AW 4513YK	220-240	50	HBP	C.S.R.	35.60	10,540	1,051	10.03	5.21	50.48	88-106	330	30	370/440	289
AW 4514YK	220-240	50	HBP	C.S.R.	37.50	11,370	1,104	10.30	5.44	54.10	88-106	330	35	370/440	324
AW 4515YK	220-240	50	HBP	C.S.R.	39.60	12,030	1,190	10.11	5.66	54.10	88-106	330	35	370/440	324
AW 4517YK	220-240	50	HBP	C.S.R.	48.40	14,660	1,487	9.86	6.80	35.00	108-130	330	20	370/440	324

208-230 V/60 Hz. (HIGH BACK PRESSURE)

AW 4495YK-2	208-230	60	HBP	C.S.R.	30.50	9,980	1,075	9.28	5.16	47.00	130-156	330	30	370/440	289
AW 4513YK-2	208-230	60	HBP	C.S.R.	35.60	12,420	1,304	9.52	6.00	73.00	108-130	330	35	370/440	289
AW 4517YK-2	208-230	60	HBP	C.S.R.	48.40	17,060	1,760	9.69	8.00	73.00	130-156	330	35	370/440	324

AW SERIES

R 22

220-240 V/50 Hz. (HIGH BACK PRESSURE)

AW 4515EK	220-240	50	HBP	C.S.R.	30.50	13,930	1,390	10.02	6.50	33.00	108-130	330	25	370/440	289
AW 4517EK	220-240	50	HBP	C.S.R.	32.70	15,140	1,536	9.86	7.62	50.48	108-130	330	30	370/440	289
AW 4519EK	220-240	50	HBP	C.S.R.	35.60	16,490	1,688	9.77	8.30	50.48	108-130	330	25	370/440	289
AW 4520EK	220-240	50	HBP	C.S.R.	37.50	17,740	1,738	10.21	7.98	54.10	108-130	330	35	370/440	324
AW 4522EK	220-240	50	HBP	C.S.R.	39.60	19,330	1,895	10.20	8.70	54.10	108-130	330	35	370/440	324
AW 4524EK	220-240	50	HBP	C.S.R.	43.10	20,950	2,089	10.03	9.64	51.30	108-130	330	45	370/440	324
AW 4528EK	220-240	50	HBP	C.S.R.	48.40	24,250	2,415	10.04	11.80	66.70	130-165	330	35	370/440	324
AW 4530EK	220-240	50	HBP	C.S.R.	50.60	25,000	2,498	10.01	12.00	73.00	88-106	330	50	370/440	324
AW 4532EK	220-240	50	HBP	C.S.R.	53.50	26,850	2,678	10.03	12.85	73.00	130-156	330	50	370/440	324
AW 5513EK	220-240	50	HBP	P.S.C.	27.80	12,060	1,270	9.50	6.38	32.30	No	No	20	370/440	289
AW 5515EK	220-240	50	HBP	P.S.C.	30.50	13,930	1,390	10.02	6.50	33.00	No	No	25	370/440	289
AW 5517EK	220-240	50	HBP	P.S.C.	32.70	15,010	1,500	10.01	7.00	35.00	No	No	30	370/440	289
AW 5519EK	220-240	50	HBP	P.S.C.	35.60	16,490	1,688	9.77	8.30	50.48	No	No	30	370/440	289
AW 5520EK	220-240	50	HBP	P.S.C.	37.50	17,740	1,738	10.21	7.98	54.10	No	No	35	370/440	324
AW 5522EK	220-240	50	HBP	P.S.C.	39.60	19,330	1,895	10.20	8.70	54.10	No	No	35	370/440	324
AW 5524EK	220-240	50	HBP	P.S.C.	43.10	20,950	2,089	10.03	9.64	51.30	No	No	45	370/440	324
AW 5528EK	220-240	50	HBP	P.S.C.	48.40	24,250	2,415	10.04	11.80	66.70	No	No	35	370/440	324
AW 5530EK	220-240	50	HBP	P.S.C.	50.60	25,000	2,498	10.01	12.00	73.00	No	No	50	370/440	324
AW 5532EK	220-240	50	HBP	P.S.C.	53.50	26,850	2,678	10.03	12.85	73.00	No	No	50	370/440	324
AW 5535EK	220-240	50	HBP	P.S.C.	59.00	29,660	3,100	9.57	15.40	85.00	No	No	60	370/440	324

208-230 V/60 Hz. (HIGH BACK PRESSURE)

AW 4528EK-2	208-230	60	HBP	C.S.R.	48.40	27,800	2,780	10.00	12.90	73.00	130-156	330	35	370/440	324
AW 4532EK-2	208-230	60	HBP	C.S.R.	53.50	31,970	3,228	9.90	15.20	89.40	130-156	330	50	370/440	324
AW 5513EK-2	208-230	60	HBP	P.S.C.	27.80	14,750	1,470	10.03	6.77	40.00	No	No	25	370/440	289
AW 5515EK-2	208-230	60	HBP	P.S.C.	30.50	16,610	1,695	9.80	8.50	47.00	No	No	25	370/440	289
AW 5517EK-2	208-230	60	HBP	P.S.C.	32.70	18,220	1,850	9.85	8.40	47.00	No	No	30	370/440	289
AW 5519EK-2	208-230	60	HBP	P.S.C.	35.60	19,640	2,039	9.63	9.33	48.00	No	No	35	370/440	289
AW 5520EK-2	208-230	60	HBP	P.S.C.	37.50	20,400	2,030	10.05	9.45	51.81	No	No	35	370/440	324
AW 5522EK-2	208-230	60	HBP	P.S.C.	39.60	22,240	2,250	9.88	10.13	51.81	No	No	30	370/440	324
AW 5524EK-2	208-230	60	HBP	P.S.C.	43.10	24,220	2,420	10.01	12.00	76.00	No	No	40	370/440	324
AW 5528EK-2	208-230	60	HBP	P.S.C.	48.40	27,870	2,830	9.85	12.90	66.00	No	No	40	370/440	324
AW 5532EK-2	208-230	60	HBP	P.S.C.	53.50	31,970	3,228	9.90	15.20	89.40	No	No	50	370/440	324
AW 5530EK-2	208-230	60	HBP	P.S.C.	50.60	30,367	3,035	10.01	14.50	89.40	No	No	50	370/440	324
AW 5535EK-2	208-230	60	HBP	P.S.C.	59.00	34,800	3,640	9.56	17.00	90.00	No	No	60	370/440	324

AW Series

Model	Voltage	Hz.	App.	Motor Type	Disp. (CC)	Cooling (BTU/Hr)	Input (W)	EER	RLA (A)	LRA (A)	Start CAP.		Run CAP.		Dim. "A"
											MFD	VAC.	MFD	VAC.	

AW SERIES **R 22**

220 V/50-60 Hz. (HIGH BACK PRESSURE)

AW 5515EK-6	220	50	HBP	P.S.C.	30.50	13,940	1,397	9.98	6.70	13.20	No	No	25	370/440	324
	220	60	HBP	P.S.C.	30.50	16,200	1,631	9.93	7.49	15.80	No	No	25	370/440	324
AW 5520EK-6	220	50	HBP	P.S.C.	37.50	17,810	1,807	9.86	9.42	58.50	No	No	35	370/440	324
	220	60	HBP	P.S.C.	37.50	20,400	2,030	10.05	9.45	51.81	No	No	35	370/440	324
AW 5522EK-6	220	50	HBP	P.S.C.	39.60	18,710	1,897	9.86	9.62	61.00	No	No	30	370/440	324
	220	60	HBP	P.S.C.	39.60	21,700	2,160	10.05	10.13	51.81	No	No	30	370/440	324
AW 5528EK-6	220	50	HBP	P.S.C.	48.40	23,810	2,370	10.05	11.77	70.00	No	No	35	370/440	324
	220	60	HBP	P.S.C.	48.40	28,130	2,807	10.02	12.85	65.00	No	No	35	370/440	324
AW 5530EK-6	220	50	HBP	P.S.C.	50.60	25,419	2,631	9.66	14.10	80.00	No	No	45	370/440	324
	220	60	HBP	P.S.C.	50.60	30,060	3,021	9.95	13.90	78.00	No	No	45	370/440	324

380-420 V/50 Hz, 460V/60Hz.-3PHASE (HIGH BACK PRESSURE)

AW 5522E-9	380-420	50	HBP	3PHASE	39.60	17,550	1,700	10.32	2.80	24.00	No	No	No	No	324
	460	60	HBP	3PHASE	39.60	21,200	2,020	10.50	2.80	24.00	No	No	No	No	324
AW 5524E-9	380-420	50	HBP	3PHASE	43.10	19,795	1,918	10.32	3.40	24.00	No	No	No	No	324
	460	60	HBP	3PHASE	43.10	23,572	2,278	10.35	3.40	24.00	No	No	No	No	324
AW 5528E-9	380-420	50	HBP	3PHASE	48.40	23,203	2,230	10.40	3.90	30.50	No	No	No	No	324
	460	60	HBP	3PHASE	48.40	28,219	2,670	10.57	3.90	30.50	No	No	No	No	324
AW 5532E-9	380-420	50	HBP	3PHASE	53.50	25,385	2,520	10.07	4.40	30.50	No	No	No	No	324
	460	60	HBP	3PHASE	53.50	31,000	3,030	10.23	4.40	30.50	No	No	No	No	324

AW SERIES **R 404A**

220-240 V/50 Hz. (LOW BACK PRESSURE)

AW 2450ZK	220-240	50	LBP	C.S.R.	37.50	4,240	929	4.56	4.42	32.00	108-130	330	15	370/440	289
AW 2462ZK	220-240	50	LBP	C.S.R.	39.60	5,200	1,116	4.66	5.10	32.00	108-130	330	20	370	289
AW 2464ZK	220-240	50	LBP	C.S.R.	43.10	5,390	1,280	4.21	6.90	43.00	130-156	330	30	370/440	324
AW 2495ZK	220-240	50	LBP	C.S.R.	53.50	7,920	1,613	4.91	8.00	56.00	145-174	330	25	440	324

208-230 V/60 Hz. (LOW BACK PRESSURE)

AW 2450ZK-2	208-230	60	LBP	C.S.R.	37.50	5,370	1,260	4.26	7.20	54.00	161-193	220/250	20	370/440	289
AW 2462ZK-2	208-230	60	LBP	C.S.R.	39.60	5,800	1,330	4.36	7.55	54.00	161-193	220/250	20	370/440	289
AW 2464ZK-2	208-230	60	LBP	C.S.R.	43.10	6,610	1,475	4.48	8.10	54.00	161-193	220/250	20	370/440	289

208-230 V/60 Hz. (MEDIUM BACK PRESSURE)

AW 7512Z-2	208-230	60	MBP	C.S.R.	37.50	12,200	2,136	5.71	11.88	58.00	161-193	330	25	440	289
AW 7516Z-2	208-230	60	MBP	C.S.R.	53.50	15,960	2,520	6.33	11.45	64.50	161-193	330	40	440	324

220-240 V/50 Hz. (MEDIUM BACK PRESSURE)

AW 7512Z	220-240	50	MBP	C.S.R.	37.50	9,900	1,687	5.87	8.40	41.80	130-156	330	30	440	289
AW 7514Z	220-240	50	MBP	C.S.R.	43.10	12,500	2,034	6.15	10.00	48.00	130-156	330	40	440	289
AW 7516Z	220-240	50	MBP	C.S.R.	53.50	19,100	3,008	6.35	15.00	52.00	130-156	330	40	440	324

380-420 V/50 Hz, 460V/60Hz.-3PHASE (LOW BACK PRESSURE)

AW 2450Z-9	380-420	50	LBP	3PHASE	37.50	4,504	925	4.87	1.90	24.00	No	No	No	No	324
	460	60	LBP	3PHASE	37.50	4,879	1,025	4.76	1.80	24.00	No	No	No	No	324
AW 2464Z-9	380-420	50	LBP	3PHASE	43.10	5,541	1,140	4.86	2.10	24.00	No	No	No	No	324
	460	60	LBP	3PHASE	43.10	5,971	1,260	4.74	2.10	24.00	No	No	No	No	324
AW 2495Z-9	380-420	50	LBP	3PHASE	53.50	7,813	1,520	5.14	3.10	30.50	No	No	No	No	324
	460	60	LBP	3PHASE	53.50	8,291	1,680	4.94	3.10	30.50	No	No	No	No	324
AW 2510Z-9	380-420	50	LBP	3PHASE	59.00	8,564	1,690	5.07	3.12	35.00	No	No	No	No	324
	460	60	LBP	3PHASE	59.00	10,031	1,990	5.04	3.12	35.00	No	No	No	No	324

AW SERIES **R 407C**

220-240 V/50 Hz. (MEDIUM BACK PRESSURE)

AW 4515GK	220-240	50	MBP	C.S.R.	30.50	6,580	1,046	6.29	4.91	33.00	108-130	330	25	370/440	289
AW 4517GK	220-240	50	MBP	C.S.R.	32.70	6,990	1,196	5.84	6.28	50.48	108-130	330	30	370/440	289
AW 4519GK	220-240	50	MBP	C.S.R.	35.60	8,390	1,320	6.36	6.20	50.48	108-130	330	25	370/440	289
AW 4520GK	220-240	50	MBP	C.S.R.	37.50	9,010	1,349	6.68	6.17	54.10	108-130	330	35	370/440	324
AW 4522GK	220-240	50	MBP	C.S.R.	39.60	9,760	1,334	7.32	6.21	54.10	108-130	330	35	370/440	324
AW 4524GK	220-240	50	MBP	C.S.R.	43.10	10,630	1,685	6.31	7.79	51.30	108-130	330	45	370/440	324
AW 4528GK	220-240	50	MBP	C.S.R.	48.40	12,390	1,865	6.64	9.33	66.70	130-156	330	35	370/440	324
AW 4532GK	220-240	50	MBP	C.S.R.	53.50	13,810	2,103	6.57	10.20	73.00	130-156	330	50	370/440	324

AW Series

Model	Voltage	Hz.	App.	Motor Type	Disp. (CC)	Cooling (BTU/Hr)	Input (W)	EER.	RLA (A)	LRA (A)	Start CAP.		Run CAP.		Dim. "A"
											MFD	VAC.	MFD	VAC.	

AW SERIES

R407C

208-230 V/60 Hz. (MEDIUM BACK PRESSURE)

AW 4524GK-2	208-230	60	MBP	C.S.R.	43.10	12,500	1,948	6.42	9.95	76.00	108-130	330	35	370/440	324
AW 4528GK-2	208-230	60	MBP	C.S.R.	48.40	14,920	2,195	6.80	10.01	73.00	130-156	330	35	370/440	324
AW 4532GK-2	208-230	60	MBP	C.S.R.	53.50	16,660	2,594	6.42	12.36	89.40	130-156	330	50	370/440	324

208-230 V/60 Hz. (HIGH BACK PRESSURE)

AW 4524GK-2	208-230	60	HBP	C.S.R.	43.10	24,220	2,420	10.01	12.00	76.00	108-130	330	35	370/440	324
AW 4528GK-2	208-230	60	HBP	C.S.R.	48.40	27,800	2,780	10.00	10.01	73.00	130-156	330	35	370/440	324
AW 4532GK-2	208-230	60	HBP	C.S.R.	53.50	31,970	3,228	9.90	15.20	89.40	130-156	330	50	370/440	324
AW 5519GK-2	208-230	60	HBP	P.S.C.	35.60	16,970	1,951	8.70	9.11	70.00	No	No	30	370/440	289

220-240 V/50 Hz. (HIGH BACK PRESSURE)

AW 4515GK	220-240	50	HBP	C.S.R.	30.50	13,930	1,390	10.02	6.50	33.00	108-130	330	25	370/440	289
AW 4517GK	220-240	50	HBP	C.S.R.	32.70	15,140	1,536	9.86	7.62	50.48	108-130	330	30	370/440	289
AW 4519GK	220-240	50	HBP	C.S.R.	35.60	16,490	1,688	9.77	8.30	50.48	108-130	330	25	370/440	289
AW 4520GK	220-240	50	HBP	C.S.R.	37.50	17,740	1,738	10.21	7.98	54.10	108-130	330	35	370/440	324
AW 4522GK	220-240	50	HBP	C.S.R.	39.60	19,330	1,895	10.20	8.70	54.10	108-130	330	35	370/440	324
AW 4524GK	220-240	50	HBP	C.S.R.	43.10	20,950	2,089	10.23	9.64	51.30	108-130	330	45	370/440	324
AW 4528GK	220-240	50	HBP	C.S.R.	48.40	24,250	2,415	10.04	11.89	66.70	130-156	330	35	370/440	324
AW 4532GK	220-240	50	HBP	C.S.R.	53.50	26,850	2,678	10.03	12.85	73.00	130-156	330	50	370/440	324
AW 5513GK	220-240	50	HBP	P.S.C.	30.50	11,530	1,317	8.75	6.17	33.00	No	No	25	370/440	289
AW 5515GK	220-240	50	HBP	P.S.C.	32.70	12,960	1,483	8.74	7.39	50.48	No	No	30	370/440	289
AW 5517GK	220-240	50	HBP	P.S.C.	35.60	14,220	1,626	8.75	7.99	50.48	No	No	30	370/440	289
AW 5518GK	220-240	50	HBP	P.S.C.	37.50	15,440	1,646	9.38	7.57	54.10	No	No	35	370/440	324
AW 5519GK	220-240	50	HBP	P.S.C.	39.60	16,880	1,808	9.34	8.32	54.10	No	No	35	370/440	324
AW 5520GK	220-240	50	HBP	P.S.C.	43.10	17,940	1,983	9.05	9.11	51.30	No	No	45	370/440	324
AW 5525GK	220-240	50	HBP	P.S.C.	48.40	21,340	2,263	9.43	11.07	66.70	No	No	35	370/440	324
AW 5527GK	220-240	50	HBP	P.S.C.	50.60	22,510	2,403	9.37	11.52	73.00	No	No	50	370/440	324

WJ Compressor

General Dimensions (mm.)

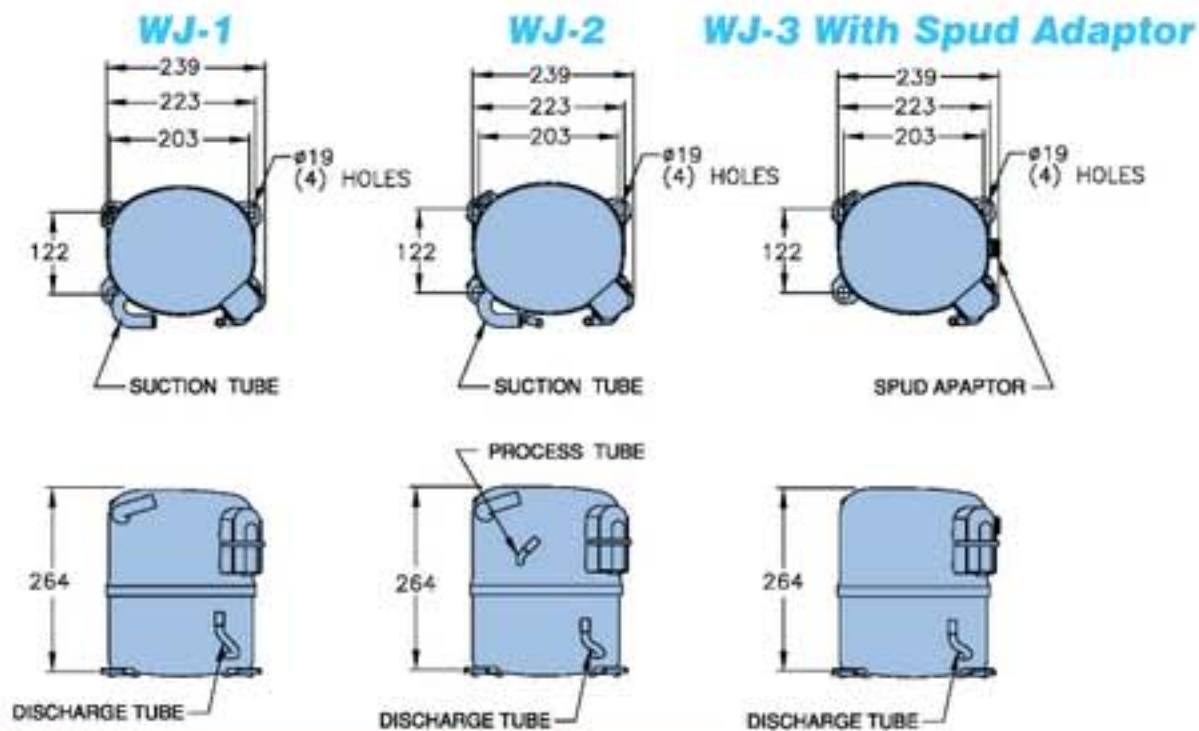

Allowed Positions For Shipping After Compressor Assembly

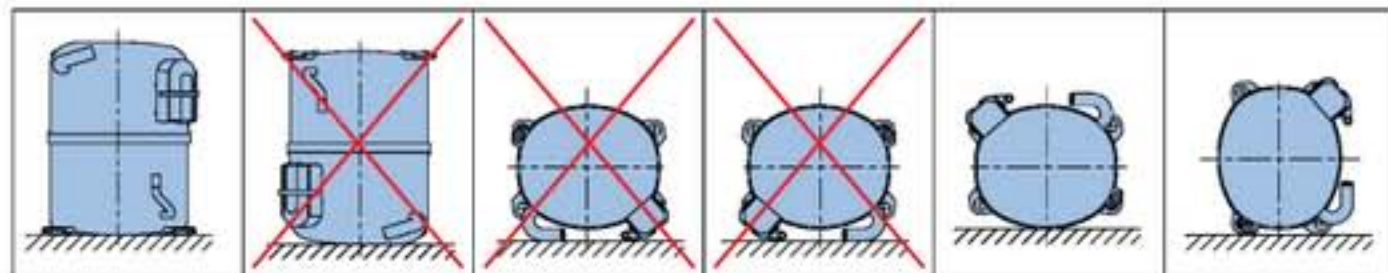

AW Series

AW Compressor

General Dimensions (mm.)

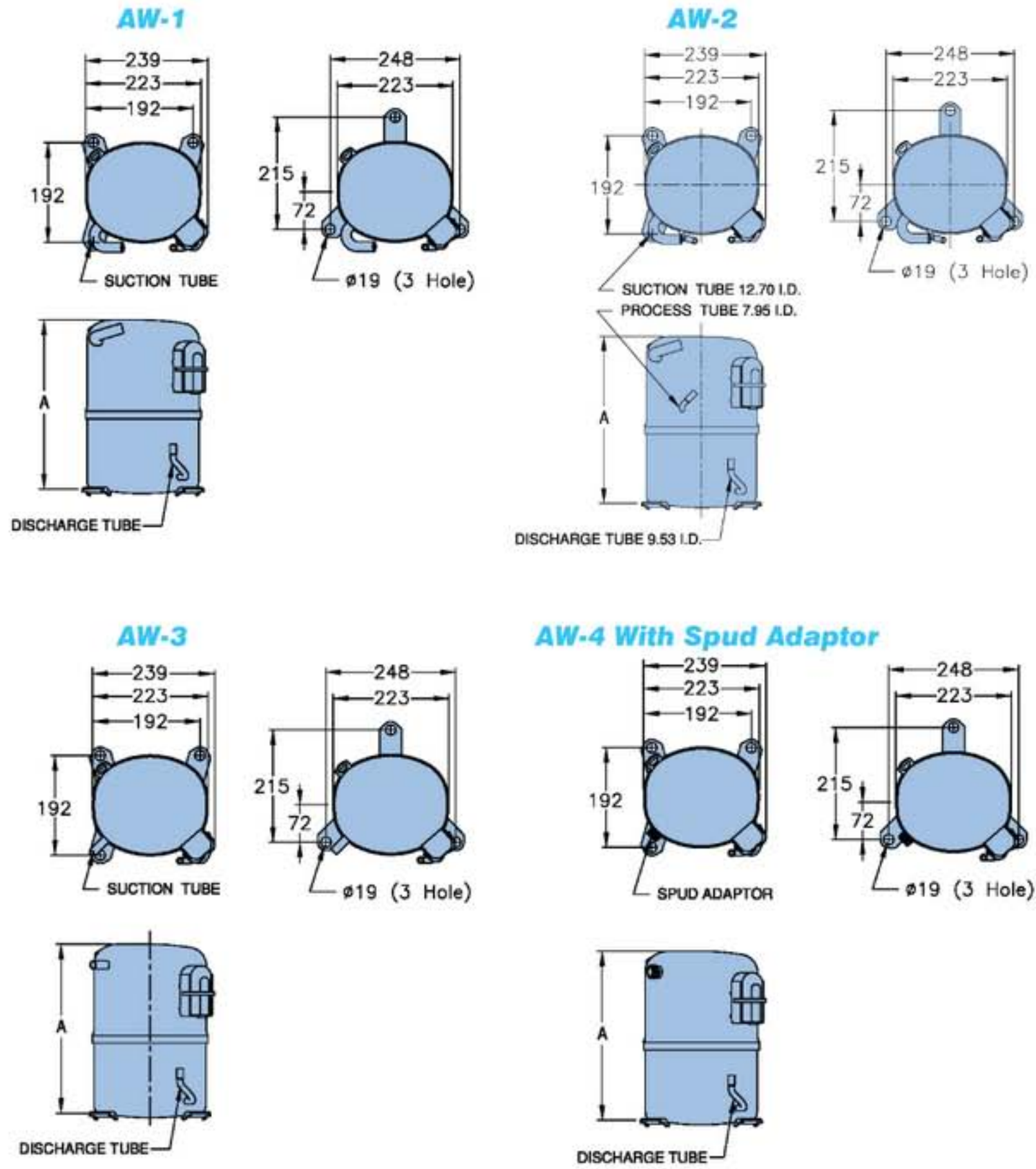

Allowed Positions For Shipping After Compressor Assembly

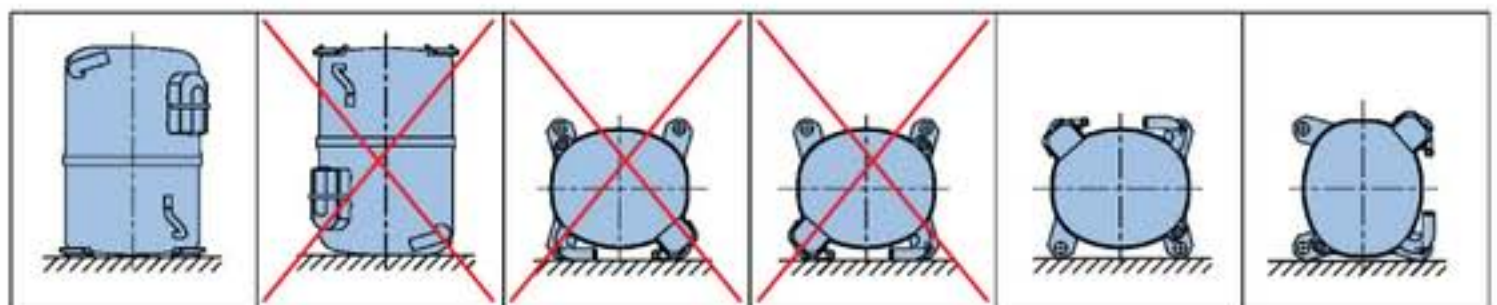

KA Series & LA Series

Model	Voltage	Hz.	App.	Motor Type	Disp. (CC)	Cooling (BTU/Hr)	Input (W)	EER	RLA (A)	LRA (A)	Start CAP.		Run CAP.		Dim. "A"
											MFD	VAC.	MFD	VAC.	

KA SERIES

R 22
380-420V/50Hz, 440-460V/60 Hz. (HIGH BACK PRESSURE)

KA 5538EXG	380-420	50	HBP	3 PHASE	65	30,700	2,790	11.00	5.70	40.00	No	No	No	No	396
	440-460	60	HBP	3 PHASE	65	37,300	3,315	11.25	5.70	43.00	No	No	No	No	396
KA 5542EXG	380-420	50	HBP	3 PHASE	70	33,900	3,040	11.15	6.00	40.00	No	No	No	No	396
	440-460	60	HBP	3 PHASE	70	40,900	3,625	11.28	6.00	43.00	No	No	No	No	396
KA 5550EXG	380-420	50	HBP	3 PHASE	80	40,600	3,650	11.12	6.80	40.00	No	No	No	No	396
	440-460	60	HBP	3 PHASE	80	49,200	4,380	11.23	6.80	43.00	No	No	No	No	396
KA 5555EXG	380-420	50	HBP	3 PHASE	90	45,900	4,100	11.20	7.90	62.00	No	No	No	No	396
	440-460	60	HBP	3 PHASE	90	55,300	5,000	11.06	8.00	70.00	No	No	No	No	396
KA 5560EXG	380-420	50	HBP	3 PHASE	100	52,400	4,680	11.19	8.70	62.00	No	No	No	No	396
	440-460	60	HBP	3 PHASE	100	58,300	5,500	10.60	10.00	70.00	No	No	No	No	396
KA 5570EXG	380-420	50	HBP	3 PHASE	115	58,000	5,466	10.61	9.94	62.00	No	No	No	No	396
	440-460	60	HBP	3 PHASE	115	70,000	6,618	11.58	10.50	70.00	No	No	No	No	396

LA SERIES

R 22
380-420V/50Hz, 440-460V/60 Hz. (HIGH BACK PRESSURE)

LA 5590EXG	380-420	50	HBP	3 PHASE	174	75,000	7,580	9.89	14.40	60.00	No	No	No	No	438
	440-460	60	HBP	3 PHASE	174	90,000	9,090	9.90	15.50	60.00	No	No	No	No	438
LA 5610EXG	380-420	50	HBP	3 PHASE	197	87,000	8,790	9.90	15.80	80.00	No	No	No	No	438
	440-460	60	HBP	3 PHASE	197	105,000	10,600	9.91	18.90	80.00	No	No	No	No	438
LA 5612EXG	380-420	50	HBP	3 PHASE	211	97,000	9,800	9.90	19.70	85.00	No	No	No	No	438
	440-460	60	HBP	3 PHASE	211	120,000	12,120	9.90	21.00	85.00	No	No	No	No	438

380V/60Hz (HIGH BACK PRESSURE)

LA 5590EXI	380	60	HBP	3 PHASE	174	90,000	9,090	9.90	15.50	70.00	No	No	No	No	438
LA 5610EXI	380	60	HBP	3 PHASE	197	105,000	10,600	9.91	18.90	120.00	No	No	No	No	438
LA 5612EXI	380	60	HBP	3 PHASE	211	120,000	12,120	9.90	21.00	85.00	No	No	No	No	438

200-220V/50Hz, 220-230V/60 Hz. (HIGH BACK PRESSURE)

LA 5590EXT	200-220	50	HBP	3 PHASE	174	75,000	7,580	9.89	22.30	121.00	No	No	No	No	438
	220-230	60	HBP	3 PHASE	174	90,000	9,090	9.90	26.70	121.00	No	No	No	No	438
LA 5610EXT	200-220	50	HBP	3 PHASE	197	87,000	8,790	9.90	27.00	208.00	No	No	No	No	438
	220-230	60	HBP	3 PHASE	197	105,000	10,600	9.91	32.70	208.00	No	No	No	No	438
LA 5612EXT	200-220	50	HBP	3 PHASE	211	97,000	9,800	9.90	19.70	85.00	No	No	No	No	438
	220-230	60	HBP	3 PHASE	211	120,000	12,120	9.90	21.00	85.00	No	No	No	No	438

Conversion Factor

Capacity in HP (Horse Power)

$$\text{HP} = \frac{\text{Performance at 60Hz in Btu/h}}{12000}$$

in High Back Pressure (HBP) and Air Conditioning (HBP-AC)

$$\text{HP} = \frac{\text{Performance at 60Hz in Btu/h}}{8000}$$

in Medium / Commercial Back Pressure (M / CBP)

$$\text{HP} = \frac{\text{Performance at 60Hz in Btu/h}}{4000}$$

in Low Back Pressure (LBP)

KA Series & LA Series

KA & LA Compressor

General Dimensions (mm.)

KA

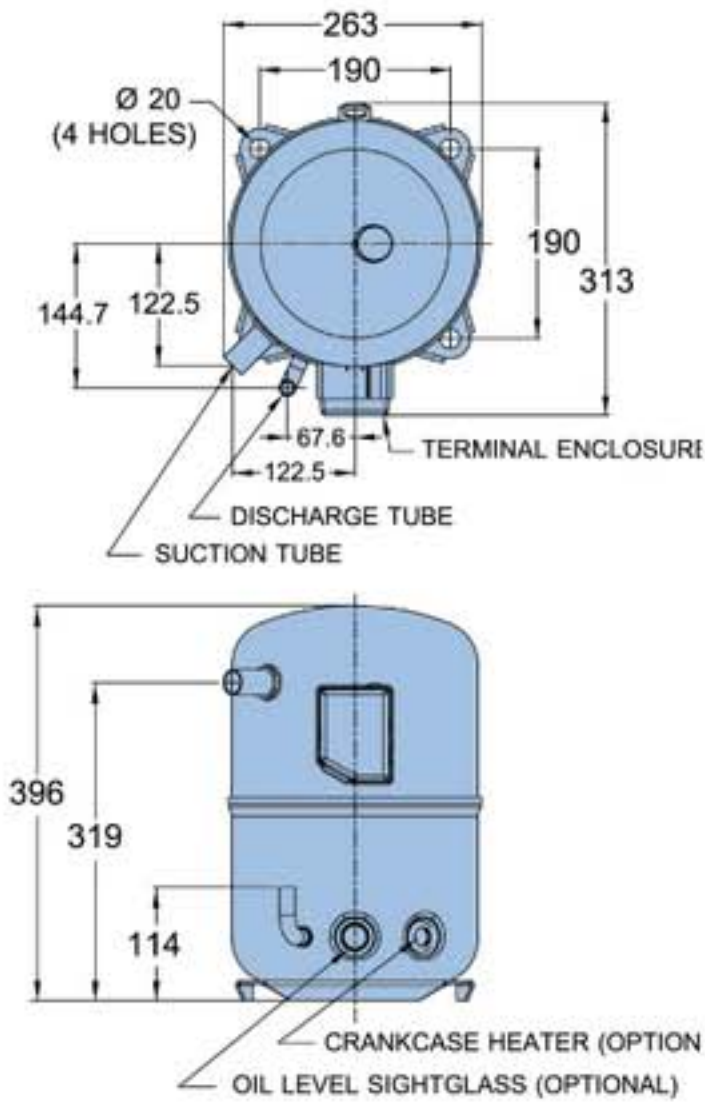

LA

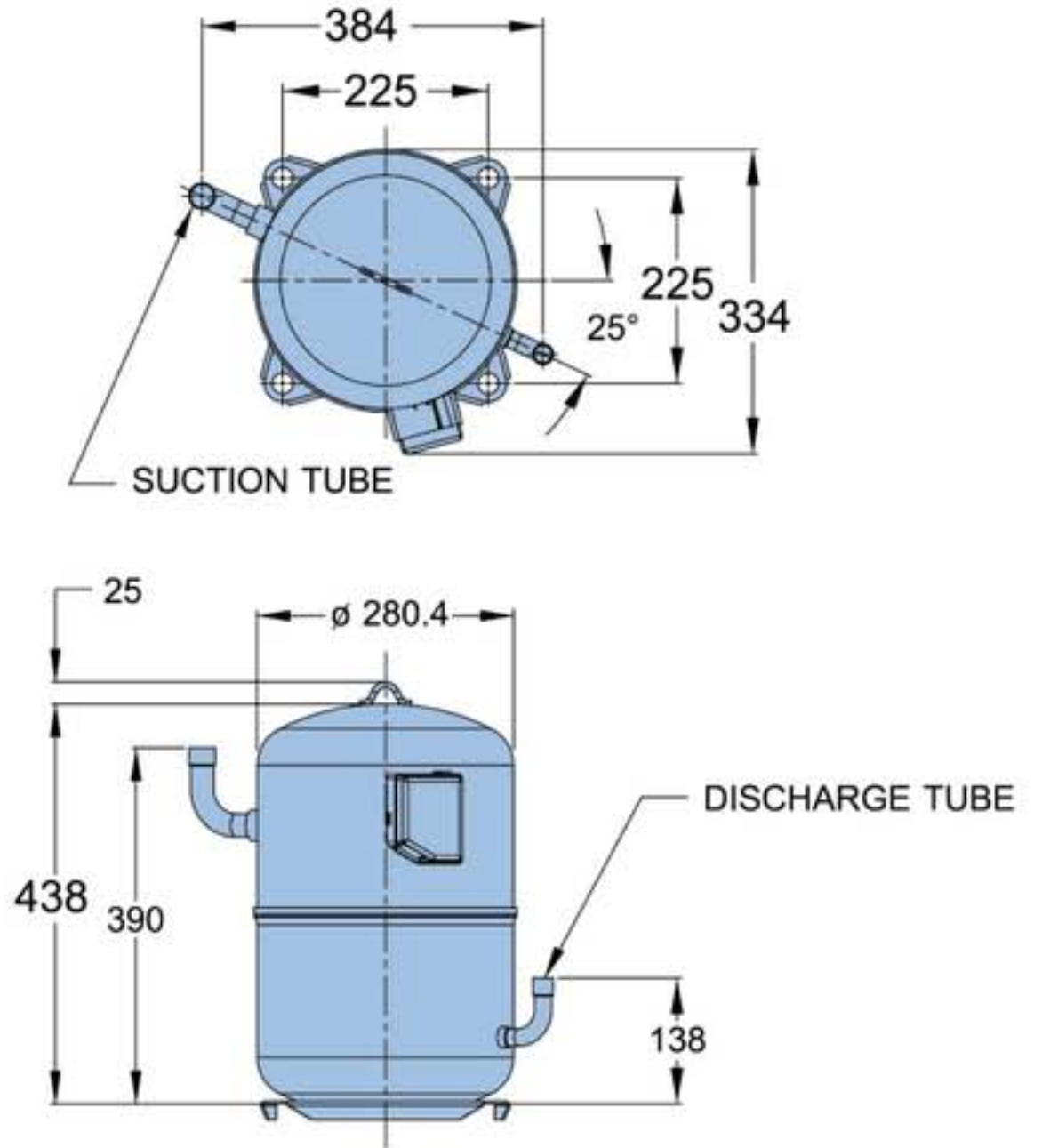

Allowed Positions For Shipping After Compressor Assembly (KA & LA)

KA

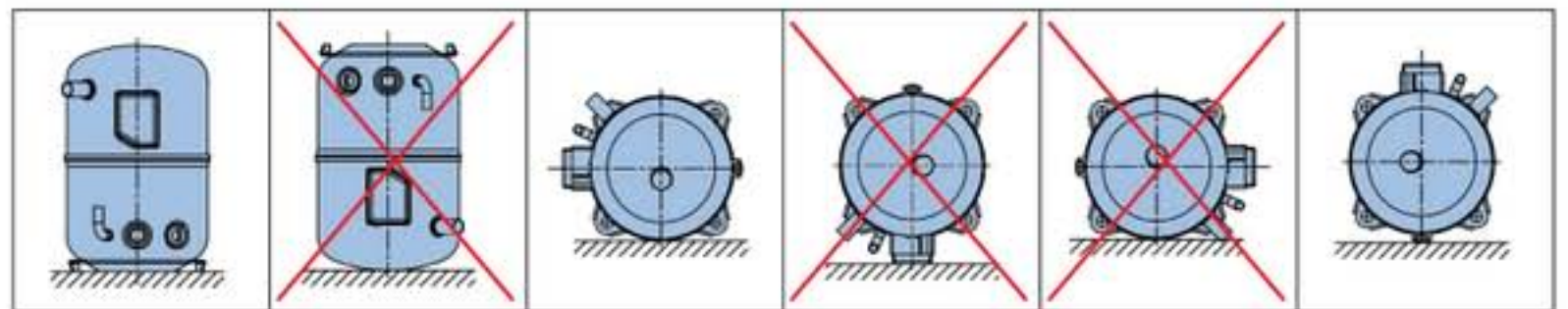

LA

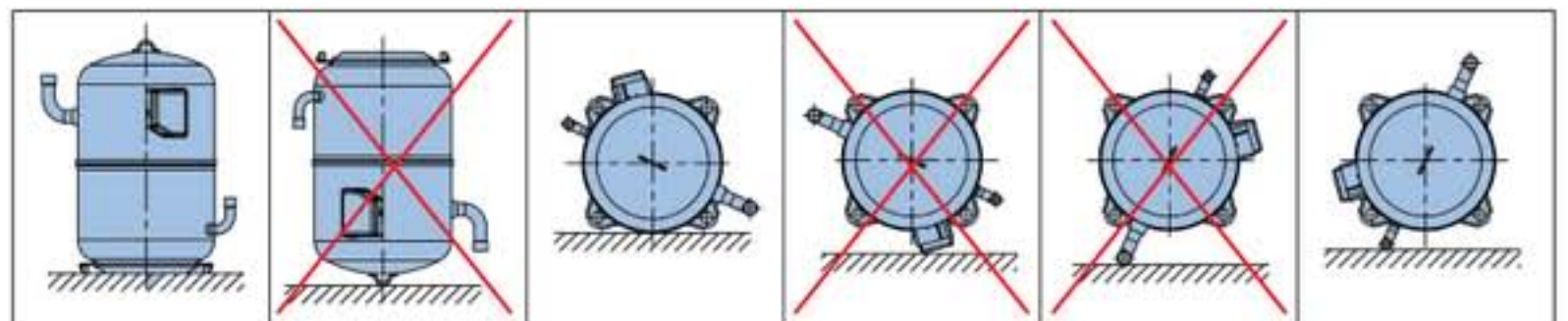

MOTOR TYPE / WIRING DIAGRAM

RSIR: Resistance Start Induction Run

RSIR motor with current relay:

The motors have a normal starting torque and are designed for completely self-equalizing capillary tube.



RSIR motor with PTC relay:

The motor functioning is similar to the RSIR with current relay motor, except for the current relay, which is replaced by the PTC relay.



RSCR: Resistance Start Capacitor Run

The motors have a PTC starting torque and a run capacitor. Their functioning is similar to the PSC motor. These compressors have a normal starting torque.

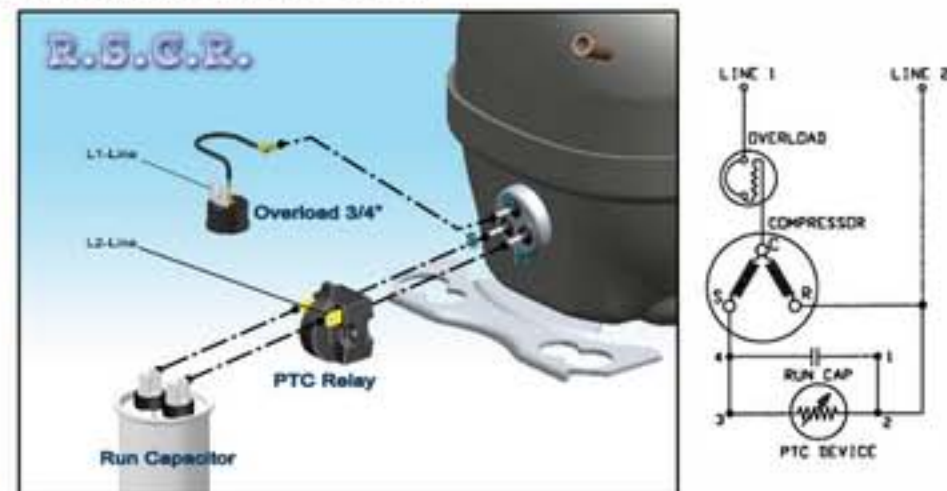

CSIR: Capacitor Start Induction Run

The motors have a high starting torque, using an electrolytic starting capacitor. Recommended for applications with capillary tube or expansion valve systems.

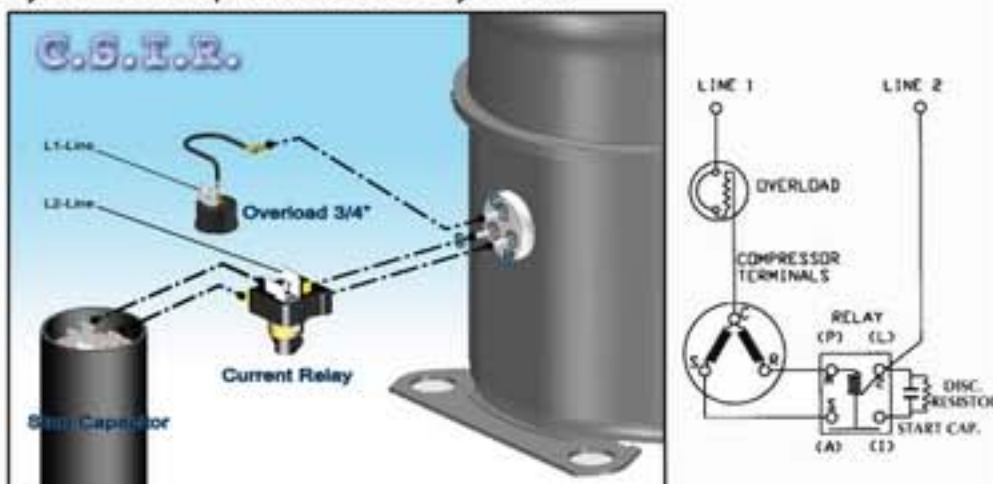

PSC: Permanent Split Capacitor

A run capacitor in series with the start winding produces a higher efficiency (EER) in comparison to a RSIR motor. They have a normal starting torque and are designed for capillary tube control devices, with equalized pressures.

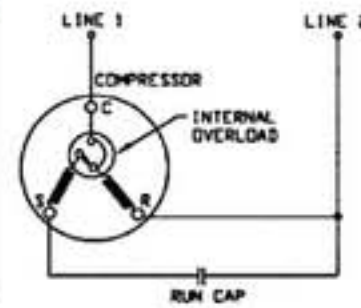
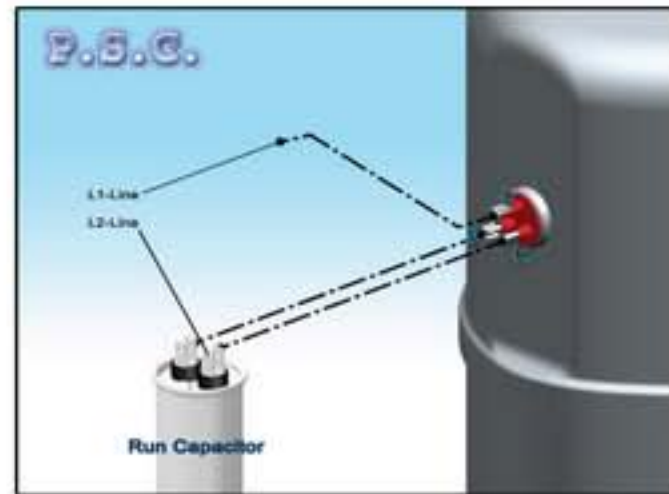

CSR: Capacitor Start Capacitor Run

This motor arrangement uses a start capacitor added to a PSC circuit. The high starting torque is suitable for unequalized systems with capillary tube or expansion valve, maintaining the same efficiency of a PSC motor.

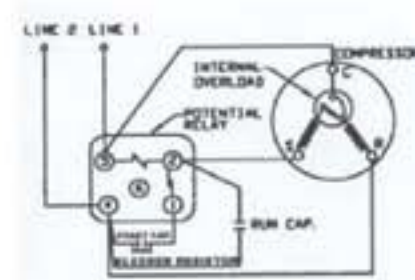
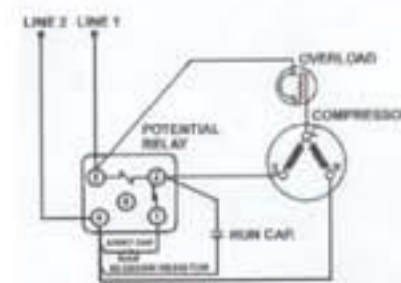
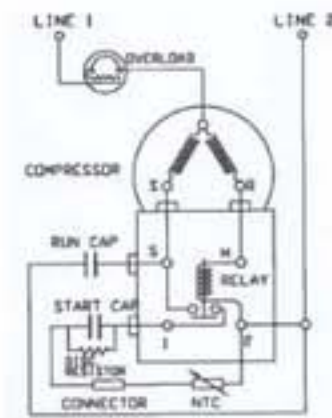

ELECTRICAL ASSEMBLY (NORMAL TYPE) FOR AE,BA SERIES

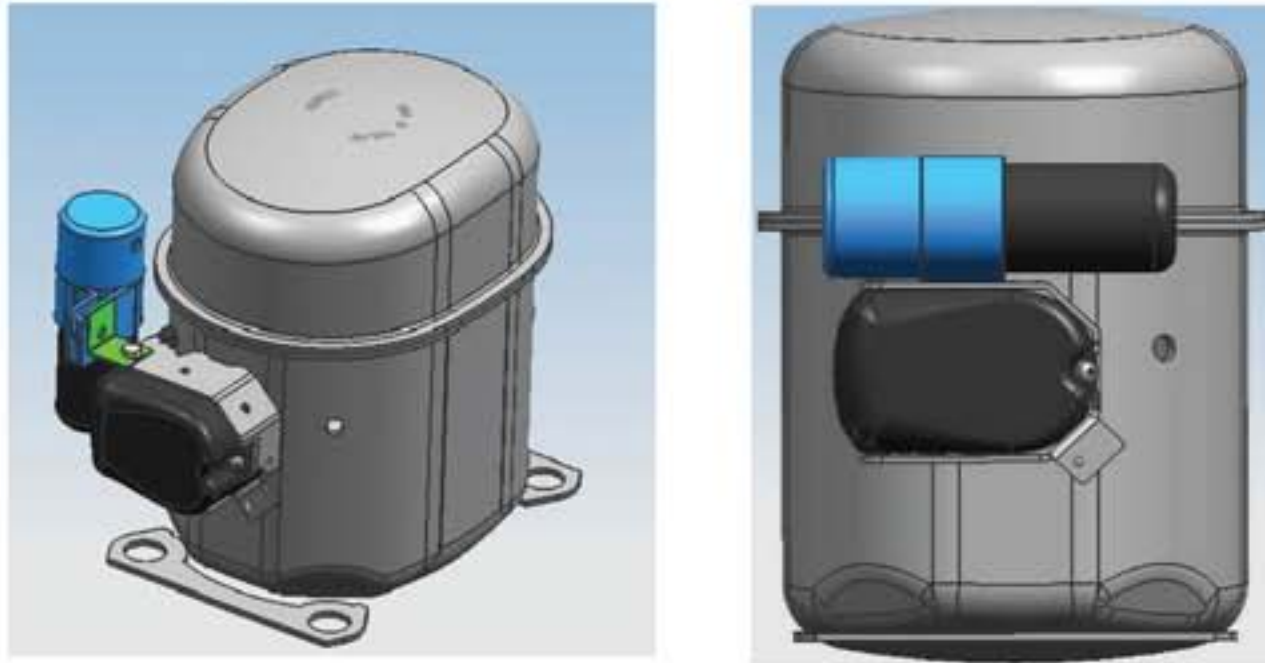

ELECTRICAL TERMINAL BOX FOR AE,BA SERIES

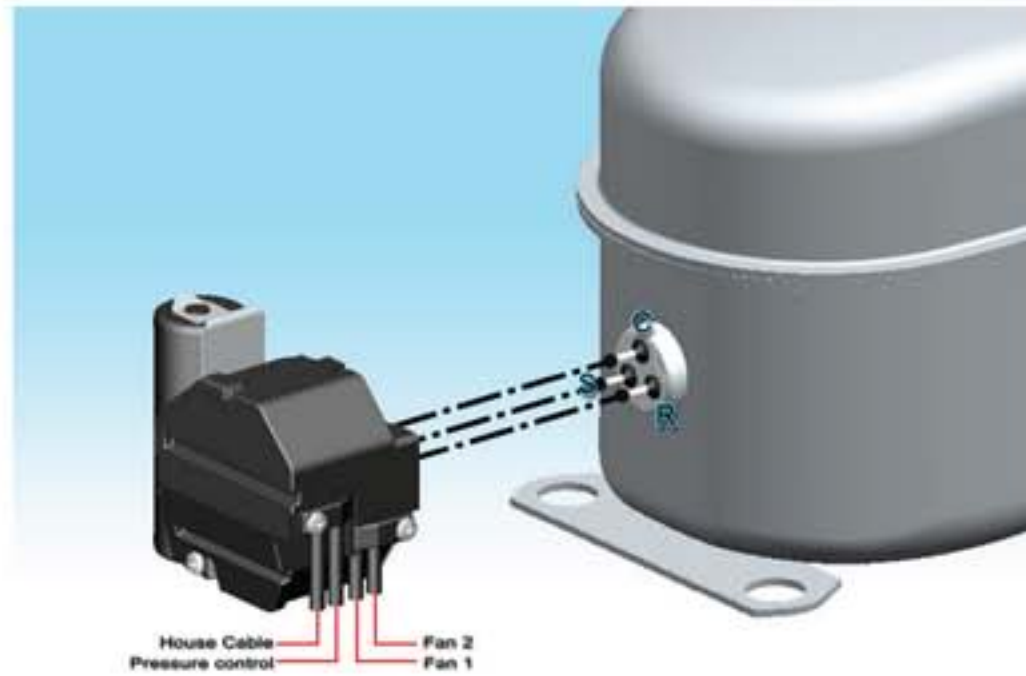

ELECTRICAL TERMINAL BOX FOR AW / WJ SERIES

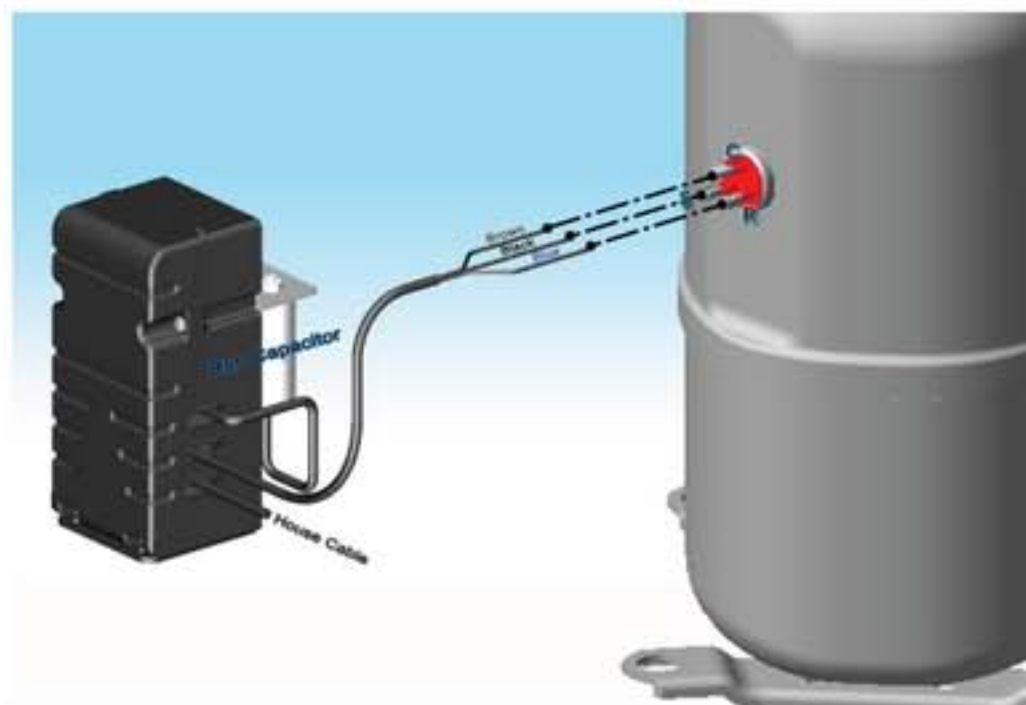

SERIAL PLATE LABEL & COMPRESSOR MOUNTING SYSTEM

Serial Plate Label



Compressor Mounting System

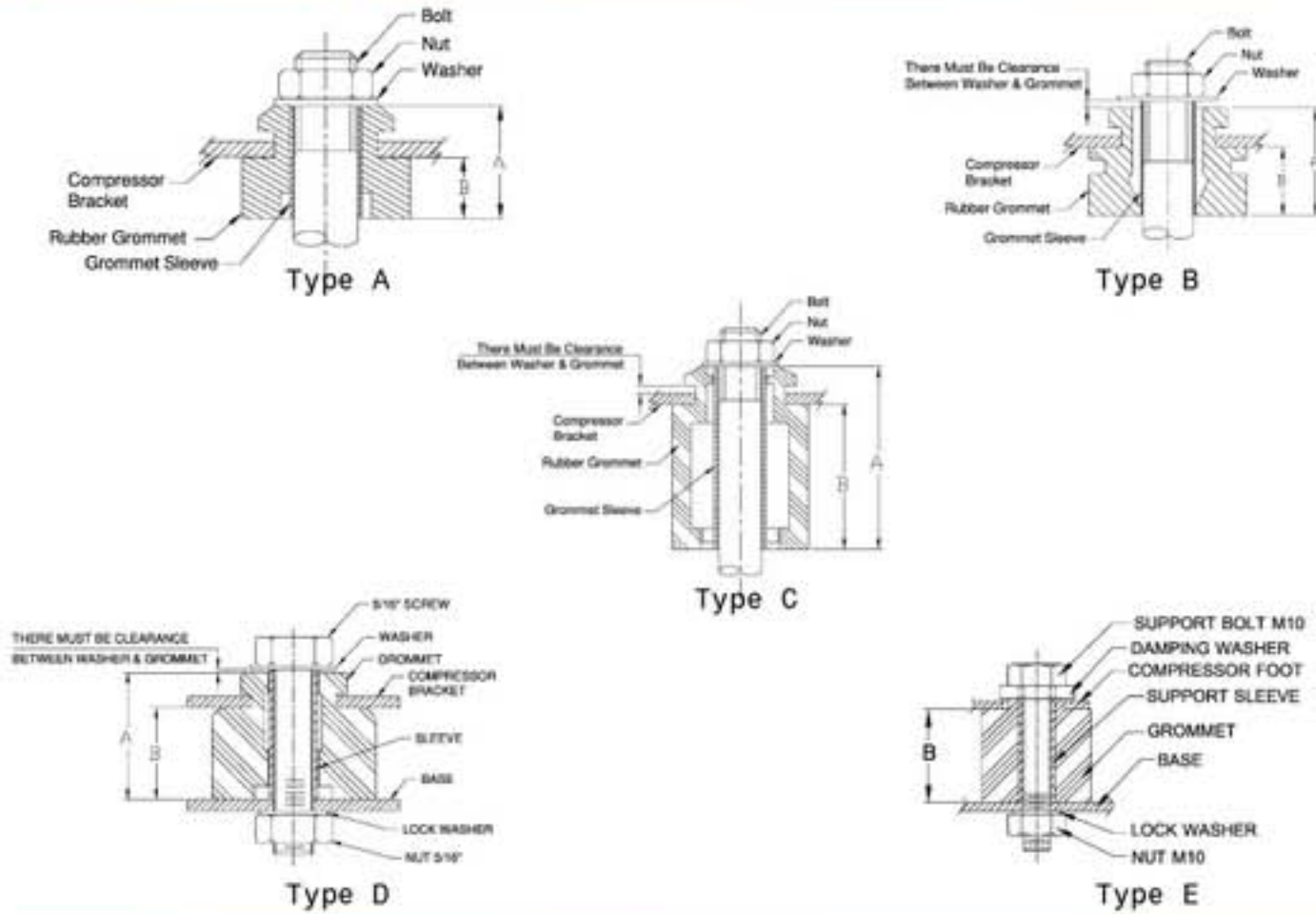

Series	Type	High "A" (mm.)	High "B" (mm.)
AZ, AZA	A	17.5	9.5
	B	21.8	13.9
AE, BA	B	21.8	13.9
	C	37	29
AW, WJ	D	28.5	20.6
KA, LA	E	-	35

KULTHORN GROUP OF COMPANIES

World - Class Products for Refrigeration and Air - Conditioning

Kulthorn Kirby Foundry Co., Ltd.

Company Registration No. : 0105532113601
 Address : 1 Moo 22 Suwintawong Road, Saladang,
 Bangnumpeaw, Chachoengsao 24000
 Telephone : (038) 593016-9
 Fax : (038) 593015
 Product : Iron Casting
 E-mail : kkf122@chloxinfo.com



Thai Sintered Products Co., Ltd.

Company Registration No. : 0105533016162
 Address : 1 Moo 22 Suwintawong Road, Saladang,
 Bangnumpeaw, Chachoengsao 24000
 Telephone : (038) 593023-7
 Fax : (038) 593022
 Product : Parts for compressor and automotive
 E-mail : preecha@thaisinter.co.th



Kulthorn Materials & Controls Co., Ltd.

Address : 1/2 Moo 22 Suvintawong Road, Saladang
 Bangnumpeaw, Chachoengsao 24000
 Telephone : (038) 593030-3
 Fax : (038) 593028
 Product : Gas Pressure Thermostat, Enameled Copper Wires
 E-mail : chamnan@kmc.in.th
 SPECIAL MAGNET COPPER WIRE FOR HERMETIC MOTOR AND OTHER HOME APPLIANCE MOTOR



Kulthorn Electric Co., Ltd.

Address : 44/2 Moo7, Latkrabang Industrial Estate, Chalongkrung RD.
 Bangkok 10520
 Telephone : (662) 2326-0527-8, 326-1204-5, 739-4767-8
 Fax : (662) 326-0128
 Product : Fractional Horsepower Motors
 (PSC and Shaded poles) for Air-Conditioners and
 Refrigeration Units
 E-mail : ku@kulthorn-electric.com





Thai Compressor Manufacturing Co., Ltd.

Company Registration No. : 0105531076303
 Address : 33/3 Moo 21 Suwintawong Road, Saladang, Bangnumpriao,
 Chachoengsao 2400
 Telephone : (038) 593063-67
 Fax : (038) 593062
 Product : Rotary compressors for air-conditioner
 E-mail : thacom@thacom.com



Company Registration No. : 0105550063921
 Address : 61/1 Moo 4 Chalongkrung Road , Khwaeng Lamplatew
 Khet Ladkrabang Bangkok 10520 Thailand
 Telephone : (662) 7396000
 Fax : (662) 3260766
 Products : Slitting, Blanking of Steel Products
 E-mail : thanawat@kulthorn.com , naree_ksc@kulthorn.com



Company Registration No. : 0105532033098
 Address : 446/3 Moo 9 Chachoengsao-Nakornratchasima Road,
 Kabinburi, Prahinburi 25100, Thailand
 Telephone : (037) 204835-41,455516-22
 Fax : (037) 455525,204187
 Product : Hermetic Motor Compressors for Refrigeration
 E-mail : hrm_kpc@kulthorn.com
 : kamjorn@kulthorn.com



Company Registration No. : 0105548043322
 Address : 61/2 Moo 4 Chalongkrung Road , Khwaeng Lamplatew
 Khet Ladkrabang Bangkok 10520 Thailand
 Telephone : (662) 7396638 - 9 , 3260314 - 7
 Fax : (662) 7396643 , 3260318
 Products : Metal Forging , Precision Machining , Heat Treatment (Carburizing)
 E-mail : kmp@kmp05.com



Address : 18 Long Pu Rd, SIP, Jiangsu Province, 215126 China
 Telephone : +86 (512) 6283 3750 / +86(512)62650058
 Fax : +86 (512) 6283 3763
 Products : Enameled Copper Wires
 E-mail : sales@pdmagnetwire.com.cn





Kulthorn Kirby
Public Company Limited

44/1 Moo 7 Chalong Krung Road, Lam Pla Thio, Lat Krabang, Bangkok 10520 Thailand
Tel: (662) 326 0831-6, 326 0529-32, 739 4893-5 Fax: (662) 326 0837, 739 4892
E-mail: kkpc@loxinfo.co.th, kkc@kulthorn.com Website: www.kulthorn.com
E-mail (Sales office): sales@kulthorn.com

KK2/2009/5K