



**Mastercool**<sup>®</sup> Inc.  
*"World Class Quality"*

**AUTOMOTIVE,  
AIR CONDITIONING,  
SERVICE TOOLS  
AND EQUIPMENT**







**Corporate Office  
Manufacturing and USA Warehouse**

For over 25 years Mastercool has been supplying professional quality air conditioning service tools and equipment. As one of the fastest growing companies in this market, our primary goal is to drive New Product Innovation and Technologies to make the every day work of the technician easier!

With our never-ending focus on innovation and new technology, Mastercool has been awarded many patents worldwide. Our products are currently being distributed in over 55 countries and growing everyday!



**In House Sensor Manufacturing**

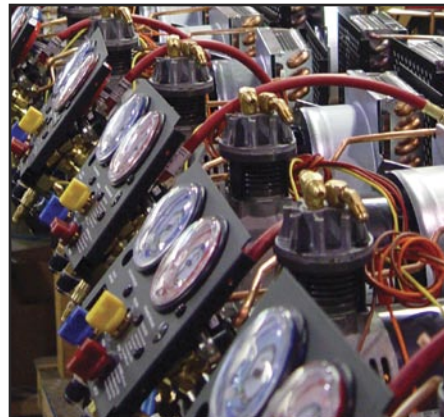

**Recovery Machine Assembly Line**



**Machining Operation**

R134a DIGITAL MANIFOLD.....	4	HOSE CRIMPING TOOLS.....	37
ALUMINUM 4-WAY MANIFOLD GAUGE SETS.....	6	TUBING TOOLS.....	38
ALUMINUM 2-WAY MANIFOLD GAUGE SETS.....	7	COMPRESSOR SERVICE TOOLS.....	40
ALUMINUM & BRASS 2-WAY MANIFOLD GAUGE SETS.....	8	COMPRESSOR TOOL CHART.....	43
GAUGES & GAUGE PROTECTORS.....	9	INDEX.....	45
CHARGING HOSES.....	10		
AUTOMATIC & MANUAL SHUT-OFF VALVES & HOSES.....	11		
COUPLERS.....	12		
A/C CHARGING ADAPTER REPAIR KITS.....	13		
CHARGING ADAPTERS, REPLACEMENT GASKETS, DEPRESSORS & RETROFIT ADAPTERS.....	14		
SERVICE TOOLS.....	15		
VALVE CORE REMOVER/INSTALLERS.....	16		
RECOVERY CYLINDERS.....	17		
VACUUM PUMPS.....	18		
CHARGING SCALES & EQUIPMENT.....	20		
RECOVERY & CHARGING EQUIPMENT.....	22		
REFRIGERANT IDENTIFIER/NITROGEN REGULATOR.....	26		
UV LEAK LOCATOR KITS.....	27		
UV LIGHTS & ACCESSORIES.....	28		
UV DYES/INJECTORS.....	29		
ELECTRONIC LEAK DETECTION.....	30		
INFRARED THERMOMETERS.....	32		
SPECIALTY HYDRAULIC TOOLS.....	34		

# R134a DIGITAL MANIFOLD

## Mastercool introduces the most advanced and user friendly R134a Digital Manifold on the Market today!

This manifold offers a large easy to read LCD that displays temperature, pressure and vacuum readings for R134a. The unit easily allows the technician to obtain refrigerant and oil capacity readings for 55 automobile manufacturers. This unit also performs systems leak check at the conclusion of the evacuation process. To insure lasting performance and durability the manifold case is constructed of ABS material and protected by a rugged rubber boot.

The technician now has a fully functional manifold with the intelligence to quickly access and deliver the accurate information needed to do the job right!



Heavy-Duty Hook Folds Back Into Unit For Compact Storage

Now Includes: Refrigerants and Oil Capacities for over 1000 Makes and Models

Protective Rubber Boot

Large Easy-To-Read LCD Screen

Keypad Control

Rugged ABS Case

Programming Connector for Software Upgrades

Aluminum Block Manifold With Double O-Ring Free Floating Piston Valves



PATENT PENDING

Patent Pending



## All the Information you Need, in the PALM OF YOUR HAND!

### DIGITAL LCD DISPLAYS:

REFRIGERANT & OIL CAPACITY  
MANUFACTURER/MODEL/YEAR

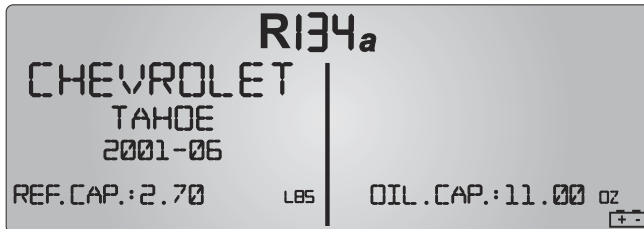

### TEMPERATURE/PRESSURE

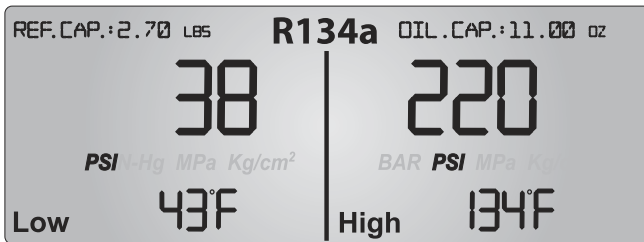

### MANUFACTURERS Included:

Acura	Honda	Mitsubishi	Smart
Alfa Romeo	Hummer	Mercedes-Benz	Subaru
Audi	Hyundai	Nissan	Suzuki
BMW	Infiniti	Oldsmobile	Toyota
Buick	Isuzu	Opel-Vauxhall	Volkswagen
Cadillac	Jaguar	Peugeot	Volvo
Chevrolet	Jeep	Plymouth	
Chrysler	KIA	Pontiac	
Citroen	Lancia	Porsche	
Daewoo	Land Rover	Renault	
Daihatsu	Lexus	Rover	
Dodge	Lincoln	SAAB	
Fiat	Mazda	Saturn	
Ford	Mercury	Scion	
GMC	Mini	Seat	

- 99134-A** Manifold only
- 99860-A** Complete Kit in a blow molded case includes: manifold with a set of 3-60" hoses and a set of manual couplers (82834 & 82934).
- 99872-A** Complete Kit in a blow molded case includes: manifold with a set of 3-72" hoses and a set of manual couplers (82834 & 82934).

**99134A-UPDT-10** USB Adapter and CD for Software Upgrade

### SPECIFICATIONS

- Refrigerant: R134a
- Pressure & Vacuum Display: Low Side - PSI, Bar, MPa, Kg/cm<sup>2</sup> & IN-Hg  
High Side - PSI, Bar, MPa, Kg/cm<sup>2</sup>
- Temperature Display: -40 to 200°F (-4 to 93°C)
- Response Time: 250 mSec.
- Connection: 1/2" ACME
- Operating Temperature: 32 to 122°F (0 to 45°C)
- Power: 9V DC battery
- Battery Life: 50-60 hours continuous use
- Low Battery Indicator: Special ICON on LCD
- Auto-Off: 15 min. with disabling capability



**Mastercool®**  
"World Class Quality"

# ALUMINUM 4-WAY MANIFOLD GAUGE SETS

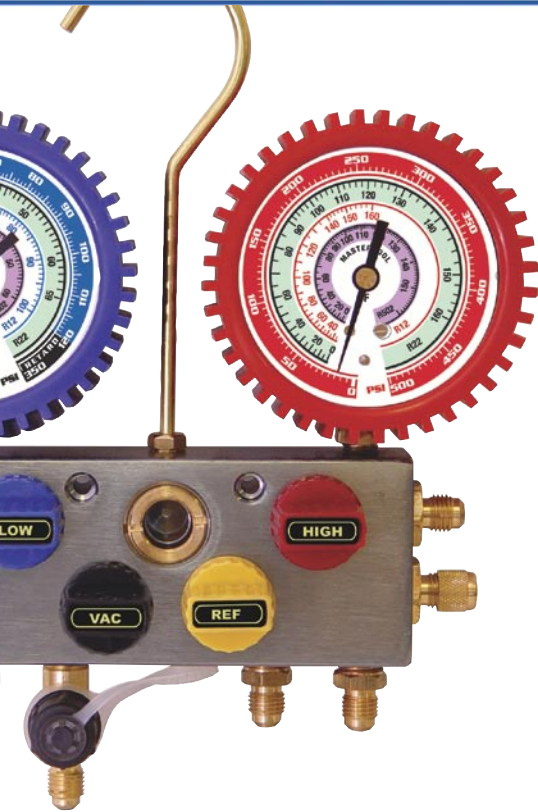

Mastercool is the leading manufacturer of professional quality AC/R manifold gauge sets. Our manifold gauge sets are constructed of the finest materials and machined with precision to the highest standards. At Mastercool, every manifold we build is built to last.

### 3/8" BORE 4-WAY BALL VALVE MANIFOLD

- Full 3/8" bore through the block increases flow considerably – faster charging & recovery
- Ball valve rotates 90° between two Teflon washers requiring little effort to turn, even under pressure
- Opens and closes quickly with only a quarter turn
- Knob position shows whether valves are open or closed (Vertical = OPEN, Horizontal = CLOSED)

### Mastercool's Aluminum 4-Way Manifolds feature PREMIER SERIES BALL VALVE DESIGN.

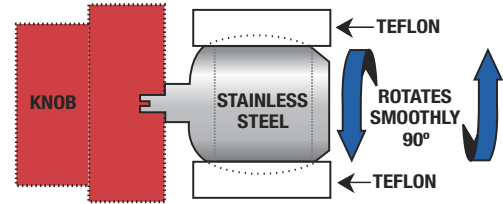

Traditional 1/4" Bore

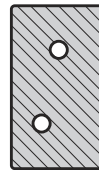

(Side Cut-away View )  
Competitor's Manifold Block  
W/1/4" bore

Mastercool's 3/8" Bore

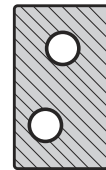

(Side Cut-away View )  
Mastercool's Manifold Block W/3/8" bore  
all the way through the block

**COMPARE!**

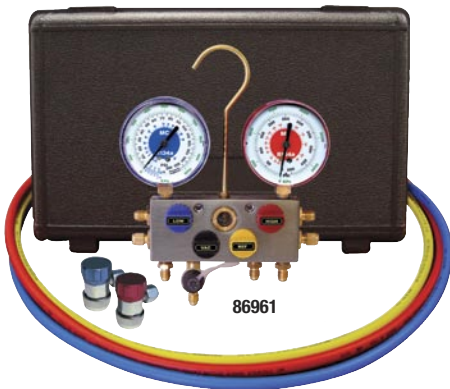

### R134a AUTO A/C 4-WAY MANIFOLD GAUGE SETS

with hoses packaged in blow molded cases. Hose connections for blue and red are 14mm-M. Yellow hose is 1/2" ACME-F with auto shut-off valve. Gauges are 3 1/8" in PSI/Kpa & °F.

HOSE LENGTH (SET OF 4)	W/O COUPLERS	W/MANUAL COUPLERS	W/E-Z SNAP™ COUPLERS
36"	86536	86936	86436
60"	86561	86961	86461
72"	86572	86972	86472

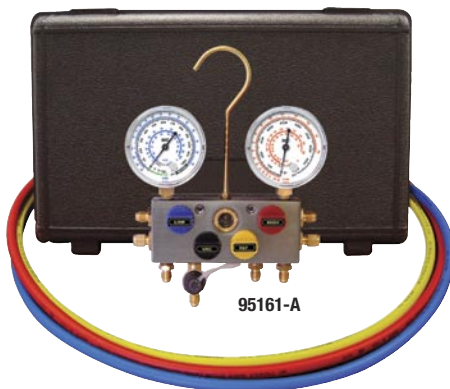

### R12, R22 AND R502 4-WAY MANIFOLD GAUGE SETS

with hoses packaged in blow molded cases. Hose connections are 1/4" SAE and gauges are 2 1/2" in PSI & °F.

HOSE LENGTH (SET OF 4)	STANDARD HOSES STANDARD FITTINGS	STANDARD HOSES AUTO SHUT-OFF VALVES	NYLON BARRIER HOSES STANDARD FITTINGS	NYLON BARRIER HOSES AUTO SHUT-OFF VALVES
36"	95136-A	95336-A	95236-A	95436-A
60"	95161-A	95361-A	95261-A	95461-A
72"	95172-A	95372-A	95272-A	95472-A

To order manifolds with shock-resistant gauge protectors, simply place a "G" after the part number.

### 4-WAY MANIFOLDS W/GAUGES ONLY

R134a  
86103 3 1/8" Gauges (1/2" ACME-M)

R12, R22, R502  
95103-A 2 1/2" Gauges (1/4" MFL)



## R134a AUTO A/C 2-WAY MANIFOLD GAUGE SETS WITH HOSES PACKAGED IN CLAMSHELLS

- Hose connections for blue and red are 14mm-M
- Yellow hose is 1/2" ACME-F with auto shut-off valve.
- Gauges are 2 1/2" in PSI/°F, 3 1/8" in PSI/Kpa & °F.

To order manifolds with shock-resistant gauge protectors, simply place a "-G" after the part no. (2 1/2" only)



HOSE LENGTH (SET OF 3)	W/MANUAL COUPLERS		W/E-Z SNAPT <sup>™</sup> COUPLERS		W/O COUPLERS	
GAUGE SIZE	2 1/2"	3 1/8"	2 1/2"	3 1/8"	2 1/2"	3 1/8"
36"	89636	89136	88436	88136	85636	85136
60"	89661	89161	88461	88161	85661	85161
72"	89772	89172	88472	88172	85772	85172

### 89660

#### AUTOMOTIVE R134a MANIFOLD GAUGE SET

- Professional Extruded Aluminum Block
- Silicone Dampened, Recalibrateable Gauges
- 3 - SAE Approved Nylon Barrier Hoses
- Professional R134a Couplers
- Custom Molded Carrying Case

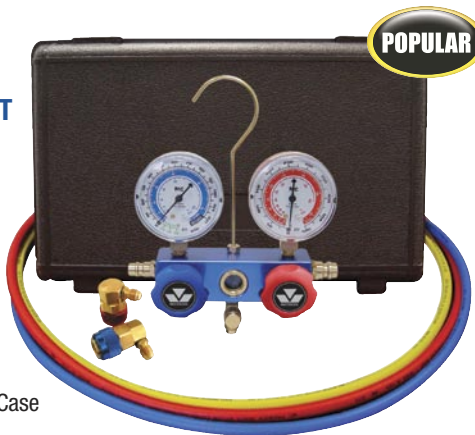

### 98660 DUAL R134a/R12 MANIFOLD GAUGE SET

- Professional Extruded Aluminum Block
- Silicone Dampened, Recalibrateable Gauges
- Set of 3 - R134a Nylon Barrier Hoses
- Set of 3 - R12 Nylon Barrier Hoses
- Professional R134a Couplers
- Custom Molded Carrying Case



### 98661 DUAL R134a/R12 MANIFOLD GAUGE SET

- Professional Extruded Aluminum Block
- Silicone Dampened, Recalibrateable Gauges
- Set of 3 - R134a Nylon Barrier Hoses
- Set of 3 - R12 Nylon Barrier Hoses
- Manual Couplers
- Custom Molded Carrying Case



### 2-WAY PISTON VALVE MANIFOLD FOR AUTO A/C - R1234yf

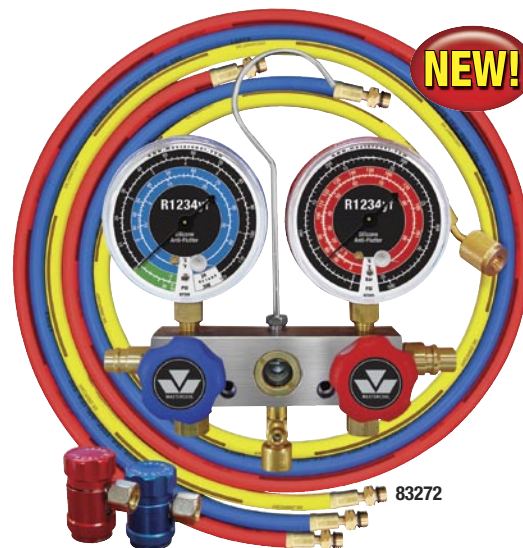

- Manifold block assembled with (3) 12mm-F fittings per SAE J2888
- Red & Blue nylon barrier hoses with 12mm-M fittings on both sides meets SAE J2888, EPA, SAE & UL standards
- Yellow hose 12mm fitting on one side and 1/2 x 16 acme LH on the other meets SAE J2888
- R1234yf high and low side couplers with extended disconnect protection sleeve meets SAE J639 & J2888
- Piston type free-floating valves reduce o-ring wear
- Extra large sight glass for visual checks of refrigerant
- Easy to recalibrate gauges to insure accuracy

Gauge size	3 1/8"
Unit	Bar/PSI
Refrigerant scales	R1234yf
Gauge p/n (LP/HP)	87350-87500
Manifold with gauges, 3 x 12mm-F fittings	<b>83102</b>
Manifold with 3 - 180cm hoses and R1234yf couplers packaged in a clam shell	<b>83272</b>

**83634** 1/4 FL-F x 1/2 acme LH male vacuum pump adapter fitting for R1234yf systems



### 2-WAY MANIFOLDS W/ GAUGES ONLY

#### R134a

**85103** 2 1/2" Gauges (1/2" ACME-M)    **85113** 3 1/8" Gauges (1/2" ACME-M)



**Mastercool<sup>®</sup>**  
"World Class Quality"

# ALUMINUM & BRASS 2-WAY MANIFOLD GAUGE SETS

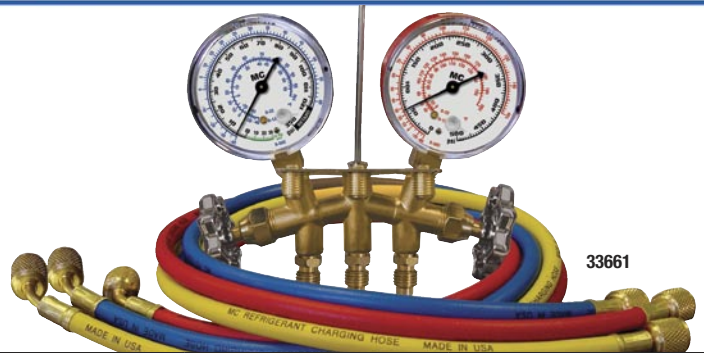

## R12, R22 AND R502 2-WAY ALUMINUM MANIFOLD GAUGE SETS WITH HOSES PACKAGED IN CLAMSHELLS

- Hose connections are 1/4" SAE
  - Gauges are 2 1/2" in PSI & °F
- To order manifolds with shock-resistant gauge protectors, simply place a "-G" after the part no. (2 1/2" only)

HOSE LENGTH (SET OF 3)	STANDARD HOSES STANDARD FITTINGS	STANDARD HOSES AUTO SHUT-OFF VALVES	NYLON BARRIER HOSES STANDARD FITTINGS	NYLON BARRIER HOSES AUTO SHUT-OFF VALVES	NYLON BARRIER HOSES MANUAL BALL VALVES
GAUGE SIZE	2 1/2"				
36"	93636	95636	96636	97636	92636
60"	93661	95661	96661	97661	92661
72"	93772	95772	96772	97772	92772

## R12, R22 AND R502 2-WAY BRASS MANIFOLD GAUGE SETS WITH HOSES PACKAGED IN CLAMSHELLS

- Hose connections are 1/4" SAE
  - Gauges are 2 1/2" in PSI & °F.
- To order manifolds with shock-resistant gauge protectors, simply place a "-G" after the part number. (2 1/2" only)

HOSE LENGTH (SET OF 3)	STANDARD HOSES STANDARD FITTINGS	STANDARD HOSES AUTO SHUT-OFF VALVES	NYLON BARRIER HOSES STANDARD FITTINGS	NYLON BARRIER HOSES AUTO SHUT-OFF VALVES	NYLON BARRIER HOSES MANUAL BALL VALVES
GAUGE SIZE	2 1/2"				
36"	33636	35636	36636	37636	32636
60"	33661	35661	36661	37661	32661
72"	33772	35772	36772	37772	32772

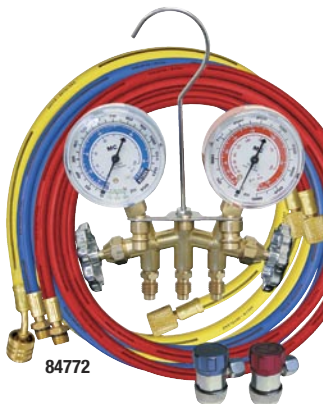

## R134a AUTO A/C 2-WAY BRASS MANIFOLD GAUGE SETS WITH HOSES PACKAGED IN CLAMSHELLS

- Hose connections for blue and red are 14mm-M, Yellow hose is 1/2" ACME-F with auto shut-off valve.
- Gauges are 2 1/2" PSI/°F, 3 1/8" in PSI/Kpa & °F.

To order manifolds with shock-resistant gauge protectors, simply place a "-G" after the part number. (2 1/2" only)

HOSE LENGTH (SET OF 3)	W/MANUAL COUPLERS		W/E-Z SNAP™ COUPLERS		W/O COUPLERS	
	2 1/2"	3 1/8"	2 1/2"	3 1/8"	2 1/2"	3 1/8"
36"	84636	84136	83436	83136	80636	80136
60"	84661	84161	83461	83161	80661	80161
72"	84772 <b>POPULAR</b>	84172	83472	83172	80772	80172

## ALUMINUM MANIFOLDS W/GAUGES ONLY

- R12, R22, R502
- 93103 2 1/2" Gauges (1/4" FL-M)

## BRASS MANIFOLDS W/GAUGES ONLY

- R134a
- 80103 2 1/2" Gauges (1/2" ACME-M)
- 81113 3 1/8" Gauges (1/2" ACME-M)
- R12, R22, R502
- 33103 2 1/2" Gauges (1/4" MFL)

## AUTOMOTIVE R134a MANIFOLD GAUGE SETS WITH ECONOMY COUPLERS

- 66660 Brass R134a Manifold Gauge Set comes complete with 1 - 60" hose, 2 - 36" hoses and economy couplers. Packaged in a clamshell.
- 66661 Brass R134a Manifold Gauge Set comes complete with 3 - 60" hoses and economy couplers. Packaged in a clamshell.





Mastercool offers one of the most extensive lines of high quality replacement gauges. Our wide variety of gauge scales are available in different sizes and styles. All of our gauges are designed with the **ANTI-FLUTTER** feature that reduces needle fluctuation and increases reading accuracy.



85350



85500



93500



93350

### 2 1/2" GAUGE MODELS

MODEL#	COMPOUND (Low Side)	MODEL#	PRESSURE (High Side)	REFRIGERANT
85350	PSI/°F	85500	PSI/°F	R134a, R12
93350	PSI/°F	93500	PSI/°F	R12, R22, R502



87350



87500



86500



86350

### 3 1/8" GAUGE MODELS

MODEL#	COMPOUND (Low Side)	MODEL#	PRESSURE (High Side)	REFRIGERANT
86350	PSI/Kpa/°F	86500	PSI/Kpa/°F	R134a
87350	Bar/PSI	87500	Bar/PSI	R1234yf



93553-E



91553-EE



### REPLACEMENT KNOBS

#### 4-Way Manifolds

58211	Blue Knob	58213	Yellow Knob
58214	Black Knob	58212	Red Knob

#### 2-Way Manifolds

85211	Blue Knob	85211-R	Blue Knob
85212	Red Knob	85212-R	Red Knob
93211	Black Knob	93211-R	Black Knob



58211 / 58212

85212-R / 85211-R

58213 / 58214

85212 / 85211

### REPLACEMENT LENSES

- 85253-E Replacement Lens for 2 1/2" gauge
- 98251-E Replacement Lens for 3 1/8" gauge



### PARTS FOR 2-WAY BRASS MANIFOLD

34215	O-rings for Brass Manifolds
34216	Seal & seat assembly for Brass Manifolds

### PARTS FOR 2-WAY ALUMINUM MANIFOLDS

85215	O-rings for Al. Manifold (4 pcs)
85216	Seal & Seat Assembly (2 pcs)

### PARTS FOR 4 WAY BALL VALVE MANIFOLDS

95102-R-KIT	O-Ring Repair Kit for 4 Way Ball Valve Manifold
-------------	---



**Mastercool**<sup>®</sup>  
"World Class Quality"

Mastercool uses only **(GRADE 5 HOSE)** with a selection of Standard and Nylon Barrier for high pressure applications. Knurled brass nuts make finger tightening easy. **Crimped with 8 segment dies for secure fit and maximum durability.** Hoses are available in sets and a variety of lengths to meet all EPA, SAE and UL requirements for containment of refrigerant.

- Sets include one blue, one red and one yellow hose

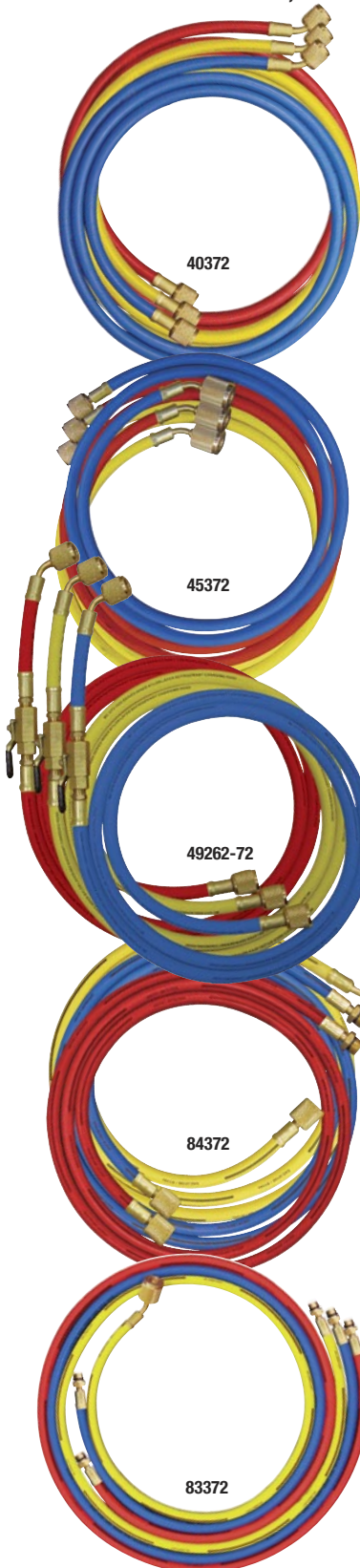

### STANDARD & HIGH PRESSURE HOSES W/STANDARD FITTINGS (1/4" SAE)

Standard Hoses, Working pressure 750 PSI, Burst 3000 PSI					Nylon Barrier Hoses, Working Pressure 800 PSI, Burst 4000 PSI				
HOSE LENGTH	36"	60"	72"	96"	HOSE LENGTH	36"	60"	72"	96"
Blue 1/4"	41361	41601	41721	41961	Blue 1/4"	47361	47601	47721	47961
Yellow 1/4"	41362	41602	41722	41962	Yellow 1/4"	47362	47602	47722	47962
Red 1/4"	41363	41603	41723	41963	Red 1/4"	47363	47603	47723	47963
Black 1/4"	N/A	N/A	N/A	N/A	Black 1/4"	47364	47604	47724	47964
Sets* 1/4"	40336	40360	40372	40396	Sets* 1/4"	47336	47360	47372	47396
Black 3/8"	N/A	N/A	N/A	N/A	Black 3/8"	48364	48604	48724	48964

### STANDARD & HIGH PRESSURE HOSES W/AUTOMATIC SHUT-OFF VALVE FITTINGS (1/4" SAE)

Standard Hoses, Working pressure 750 PSI, Burst 3000 PSI					Nylon Barrier Hoses, Working Pressure 800 PSI, Burst 4000 PSI				
HOSE LENGTH	36"	60"	72"	96"	HOSE LENGTH	36"	60"	72"	96"
Blue 1/4"	45361	45601	45721	45961	Blue 1/4"	46361	46601	46721	46961
Yellow 1/4"	45362	45602	45722	45962	Yellow 1/4"	46362	46602	46722	46962
Red 1/4"	45363	45603	45723	45963	Red 1/4"	46363	46603	46723	46963
Black 1/4"	N/A	N/A	N/A	N/A	Black 1/4"	46364	46604	46724	46964
Sets* 1/4"	45336	45360	45372	45396	Sets* 1/4"	46336	46360	46372	46396

Auto shut-off valves automatically retain refrigerant in the service hose when they are removed from the system, meet EPA, SAE and UL standards for containment of refrigerant.

### STANDARD & HIGH PRESSURE HOSES W/MANUAL SHUT-OFF VALVE FITTINGS (1/4" SAE)

Standard Hoses, Working pressure 750 PSI, Burst 3000 PSI				Nylon Barrier Hoses, Working Pressure 800 PSI, Burst 4000 PSI			
HOSE LENGTH	36"	60"	72"	HOSE LENGTH	36"	60"	72"
Blue 1/4"	90263-36	90263-60	90263-72	Blue 1/4"	49263-36	49263-60	49263-72
Yellow 1/4"	90264-36	90264-60	90264-72	Yellow 1/4"	49264-36	49264-60	49264-72
Red 1/4"	90265-36	90265-60	90265-72	Red 1/4"	49265-36	49265-60	49265-72
Sets* 1/4"	90262-36	90262-60	90262-72	Sets* 1/4"	49262-36	49262-60	49262-72

### R134a HOSES WITH 1/2" ACME-F AND 14MM-M AUTO A/C FITTINGS

HOSE LENGTH	36"	60"	72"	96"
Blue-14mm-M x 1/2" ACME-F	84361	84601	84721	84961
Yellow w/Shut-off Valve-1/2" ACME-F	84362	84602	84722	84962
Red-14mm-M x 1/2" ACME-F	84363	84603	84723	84963
Black-1/2" ACME-F	84364	84604	84724	84964
Black Conversion Hose 1/2" ACME-F x 1/4" FL-F	98364	98604	98724	98964
Yellow without Shut-off Valve	84365	84605	84725	84965
Sets*	84336	84360	84372	84396

Mastercool R134a charging hoses meet SAE J2196 specifications and are UL tested. Tested for working pressure of 600 PSI and burst pressure of 3000 PSI.

### R1234yf HOSES (Meets J2888, EPA, SAE & UL Standards)

Nylon Barrier Hoses, Working Pressure 56 BAR, Burst 280 BAR	
HOSE LENGTH	180cm
Blue-12mm-M x 12mm-M	83721
Yellow-12mm fitting x 1/2 x 16 ACME LH	83722
Red-12mm-M x 12mm-M	83723
SET Blue/Red 12mm-M x 12mm-M and Yellow 12mm fitting x 1/2 x 16 ACME LH	83372





Mastercool manufactures a complete line of shut-off valves for containment of refrigerant. EPA requires shut-off valves within 12 inches of the charging hose ends to prevent unnecessary venting of refrigerant. Using shut-off valves is much safer than allowing refrigerant to blow out during service.

## 90259 90° MANUAL SHUT-OFF VALVE SET

Needle valve design with flexible hose controls refrigerant with a twist of a knob. Meets SAE, EPA and UL requirements for containment of refrigerant. Screws onto charging hose end.

90° Manual Shut-Off Valve Set Includes:

**90269** Blue 1/4 x 1/4"

**90279** Yellow 1/4 x 1/4"

**90289** Red 1/4 x 1/4"

**Also Available:**

**90389** Red 1/4 x 3/16"  
(Automotive)



## 90262 STRAIGHT MANUAL SHUT-OFF VALVE SET

Ball valve design with flexible hose controls refrigerant with a quarter turn of the valve handle. Meets SAE, EPA and UL requirements for containment of refrigerant. One hand operation. Screws onto charging hose end. Straight and Manual Shut-Off Valve Set includes:

**90263** Blue 1/4 x 1/4"

**90264** Yellow 1/4 x 1/4"

**90265** Red 1/4 x 1/4"

**Also available:**

**90365** Red 1/4 x 3/16"

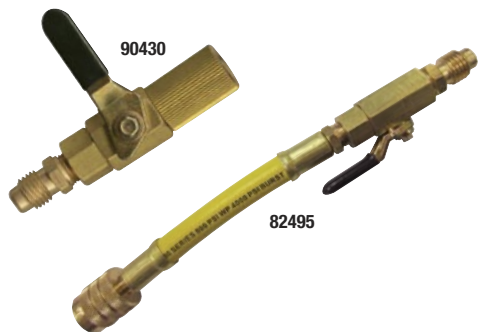
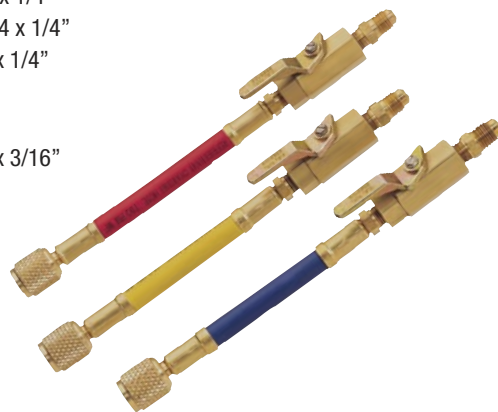

**QUICK DISCONNECT**  
No Loss of Refrigerant

## AUTOMATIC SHUT-OFF VALVES

Valve simply screws onto hose end. Available in straight and 90° models. Meets SAE, EPA and UL requirements for containment of refrigerant.

**90333-R** 90° 1/4 FL-M x 1/4 FL-F    **90335-R** Straight 1/4 FL-M x 1/4 FL-F  
**90333-UV** 90° 1/4" FFL x 13mm    **90337** Straight 1/4 FL-M x 3/16 FL-F

## MANUAL SHUT-OFF BALL VALVES

For custom application, Mastercool offers swivel ball valves without the hoses. This valve may be used to add shut-off valves to recycling equipment, manifold sets, flushing equipment, etc.

**90430** 1/4 FL-F x 1/4 FL-M Swivel Ball Valve (less hose)

**82495** 1/2" ACME x 1/2" ACME R134a Ball Valve

## CONTROL VALVE

Ideal for use on charged systems. Eliminates refrigerant, oil or dye from spraying during connections. Brass body with 1/4" FFL swivel coupler.

**90328** 1/4" FFL x 1/4" MFL



## SERVICE HOSE REPLACEMENT PARTS

	1/4" SAE		1/2" ACME		14mm-M O-RING	UNF 1/2 - 20"	
	GASKET	DEPRESSOR	GASKET	DEPRESSOR		GASKET	DEPRESSOR
Charging Hoses	<b>42010-10</b>	<b>42014-10</b>	<b>82010-10</b>	<b>42014-10</b>	<b>83341-10</b>	<b>42010-10</b>	<b>42014-10</b>
Shut-Off Valve	<b>90336-10</b>	N/A	<b>82336-10</b>	N/A	N/A	N/A	N/A



**Mastercool®**  
"World Class Quality"

# COUPLERS



## MANUAL COUPLERS

Patented manual couplers adjust easily to R134a service ports with varying dimensions. All metal construction for extra durability. Patented, spring loaded depressor will not damage service valves. Can be removed from service ports regardless of knob position without losing refrigerant. Meets SAE, UL and EPA requirements for containment of refrigerant. Color coded. **PATENT# 5,370,359**

<b>82834</b>	High-Side Manual R134a 14mm-F x 16mm Quick Coupler
<b>82934</b>	Low-Side Manual R134a 14mm-F x 13mm Quick Coupler
<b>82834-E</b>	High-Side Manual R134a 1/4" FL-M x 16mm Quick Coupler
<b>82934-E</b>	Low-Side Manual R134a 1/4" FL-M x 13mm Quick Coupler
<b>80034</b>	O-ring for 16mm Quick Coupler (10 pcs)
<b>80134</b>	O-ring for 13mm Quick Coupler (10 pcs)

## ECONOMY COUPLERS

Specially designed to work in the tightest quarters. Attaches to your existing R12 hoses and snaps easily to A/C service ports.

<b>66434-R</b>	High Side R134a 1/4" FL-M x 16mm Economy Coupler
<b>66534-R</b>	Low Side R134a 1/4" FL-M x 13mm Economy Coupler
<b>60034-10</b>	O-ring for 66434 (10 pcs)
<b>60134-10</b>	O-ring for 66534 (10 pcs)



## R134a EXTRA LONG COUPLERS

Extra Long High Side R134a coupler used on BMW E60 (2003-2009 5 series) and some volvo models. This extra long high side coupler can easily reach the service port.

<b>82836</b>	High Side Extra Long 14mm-F x 16mm
<b>82836-E</b>	High Side Extra Long 1/4" SAE-M x 16mm



## R1234yf COUPLERS

- High and low couplers with extended disconnect protection sleeve
- Meets SAE J639 & J2888
- Allows recovery of entire refrigerant, including the space between the coupler and fitting.

<b>83834</b>	High Side R1234yf Coupler
<b>83934</b>	Low Side R1234yf Coupler



## E-Z SNAP™ COUPLERS

This unique patented design easily snaps on and off the A/C systems service ports under any pressure. The E-Z Snap™ automatically adjusts to various service port dimensions allowing fast and immediate access into the A/C system. The swivel feature enables the user to easily access all service ports, even in the tightest quarters. Meets SAE, UL, and EPA requirements for containment of refrigerant. **PATENT# 5,244,010**

<b>82214</b>	High-Side E-Z Snap R134a 14mm-F x 16mm Quick Coupler
<b>82224</b>	Low-Side E-Z Snap R134a 14mm-F x 13mm Quick Coupler
<b>82214-E</b>	High-Side E-Z Snap R134a 1/4" FL-M x 16mm Quick Coupler
<b>82224-E</b>	Low-Side E-Z Snap R134a 1/4" FL-M x 13mm Quick Coupler
<b>80034</b>	O-ring for 16mm Quick Coupler (10 pcs)
<b>80134</b>	O-ring for 13mm Quick Coupler (10 pcs)

## 98370 R134a CONVERSION KIT

Includes High and Low Side R134a Couplers and R134a Tank Adapter.

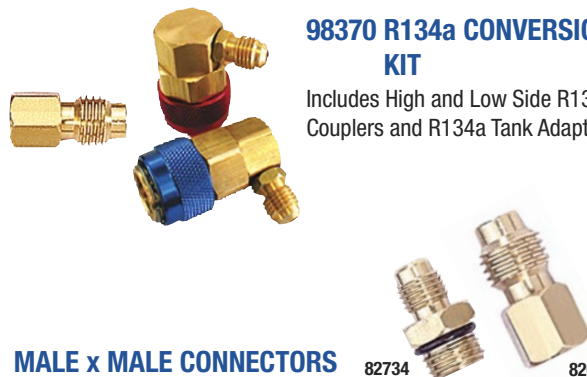

## MALE x MALE CONNECTORS

PART#	DESCRIPTION
<b>82734</b>	14mm-M x 1/4" FL-M (7/16-20") Connector
<b>82735</b>	14mm-M x M10 x 1.5-M Connector
<b>82736</b>	14mm-M x M12 x 1.75-M Connector
<b>82738</b>	14mm-M x 3/8" FL-M Connector
<b>83341</b>	O-Ring for 82733, 82734, 82735 and 82736
<b>80234</b>	O-Ring for 82634, 82634-M, 90364 and 90365

## FEMALE x MALE CONNECTORS

PART#	DESCRIPTION
<b>82635</b>	1/2" ACME-F x 1/4" FL (7/16-20")-M R134a Adapter Coupler
<b>82733</b>	14mm-F x 1/2" ACME-M Connector
<b>90364</b>	1/4" (7/16-20")-F x M10 x 1.5-M Adapter
<b>90363</b>	5/16" (1/2-20 UNF)-F x 1/4" FL-M Connector
<b>82634</b>	1/4" FL-F (7/16-20") x 1/2" ACME-M Connector
<b>82634-M</b>	1/4" FL-F (7/16-20") x 1/2" ACME-M R134a Connector





## 91207 CHARGING AND DEPRESSOR ASSORTMENT

Replacement gaskets, o-rings and depressors for charging hoses and adapters.

Consists of:

- |                                      |                                   |
|--------------------------------------|-----------------------------------|
| <b>42010</b> 1/4" Gasket (3 pcs)     | <b>90369</b> 3/16" Gasket (3 pcs) |
| <b>42014</b> 1/4" Depressor (3 pcs)  | <b>90341</b> 1/8" O-ring (3 pcs)  |
| <b>90368</b> 3/16" Depressor (3 pcs) |                                   |



## 91334 CHARGING ADAPTER REPAIR KIT

55 piece assortment of replacement gaskets, o-rings and depressors for charging hoses and adapters. Consists of:

- |                                       |  |
|---------------------------------------|--|
| <b>42010</b> 1/4" Gasket (10 pcs)     | <b>90369</b> 3/16" Gasket (10 pcs)           |
| <b>42014</b> 1/4" Depressor (10 pcs)  | <b>90341</b> 1/8" O-ring (10 pcs)            |
| <b>90368</b> 3/16" Depressor (10 pcs) | <b>92107</b> Quick Disconnect Gasket (5 pcs) |



## 85200 DELUXE A/C SERVICE REPAIR KIT

Replacement gaskets, depressors, o-rings and nylon guides for charging hoses and adapters. Consists of:

- |  |   |
|--|---|
| <b>42010</b> 1/4" Gasket (10 pcs)            | <b>80134-1</b> Low Side Nylon Guide (5 pcs)         |
| <b>42014</b> 1/4" Depressor (10 pcs)         | <b>82010</b> Gasket for R134a Hose (10 pcs)         |
| <b>80034</b> O-ring for 82834 (10 pcs)       | <b>82336</b> Gasket for 82335 (10 pcs)              |
| <b>80034-1</b> High Side Nylon Guide (5 pcs) | <b>83341</b> O-ring for R134a Hose (10 pcs)         |
| <b>80134</b> O-ring for 82934 (10 pcs)       | <b>90336</b> Gasket for R12 Shut-off Valve (10 pcs) |



**NEW!**

## 91334-A R12/R134a CHARGING HOSE REPLACEMENT PARTS ASSORTMENT

- |   |   |
|---|---|
| <b>42010</b> 1/4" FL Gasket (10 pcs)      | <b>82010</b> Black Gasket for R134a Hose (10 pcs) |
| <b>42014</b> 1/4" FL Depressor (5 pcs)    | <b>83341</b> O-Ring for R134a Hose (5 pcs)        |
| <b>42016</b> Screw Type Depressor (5 pcs) | <b>80034-2</b> Black O-Ring for High Side (5 pcs) |
| <b>90336</b> Gasket for 90335 (5 pcs)     | <b>80132-2</b> Black O-Ring for Low Side (5 pcs)  |



## 91335 MASTER A/C CHARGING ADAPTER REPAIR KIT

126 piece assortment of replacement gaskets, o-rings and depressors for charging hoses and adapters. Also includes valve core removal tool and replacement valve cores. Consists of:

- |                                       |   |
|---------------------------------------|---|
| <b>42010</b> 1/4" Gasket (20 pcs)     | <b>92107</b> Quick Disconnect Gasket (10 pcs)     |
| <b>42014</b> 1/4" Depressor (20 pcs)  | <b>0377-001</b> Refrigeration Valve Core (10 pcs) |
| <b>90368</b> 3/16" Depressor (20 pcs) | <b>90378</b> GM Large Bore Valve Core (5 pcs)     |
| <b>90369</b> 3/16" Gasket (20 pcs)    |   |
| <b>90341</b> 1/8" O-ring (20 pcs)     |   |



## 91336 FORD SPRING LOCK REPLACEMENT O-RING AND GARTER SPRING ASSORTMENT

Compatible with R12 and R134a systems. Consists of:

- |                                     |   |
|-------------------------------------|---|
| <b>1336-006</b> #6 O-ring (10 pcs)  | <b>1336-016</b> #6 Garter Spring (5 pcs)  |
| <b>1336-008</b> #8 O-ring (10 pcs)  | <b>1336-018</b> #8 Garter Spring (5 pcs)  |
| <b>1336-010</b> #10 O-ring (10 pcs) | <b>1336-110</b> #10 Garter Spring (5 pcs) |
| <b>1336-012</b> #12 O-ring (10 pcs) | <b>1336-112</b> #12 Garter Spring (5 pcs) |



## 91337 R12/R134a VALVE CORE REPAIR KIT

Replacement valve cores for valve core removers & installers. Consists of:

- |   |
|---|
| <b>0377-001</b> Access Valve Core (20 pcs)                      |
| <b>0378-001</b> Valve Core (10 pcs)                             |
| <b>0531-001</b> R134a JRA High/Low Import Valve Core (10 pcs)   |
| <b>0768-001</b> R134a Domestic High Flow Valve Core M8 (5 pcs)  |
| <b>0769-001</b> R134a Domestic High Flow Valve Core M10 (5 pcs) |
| <b>81290</b> R12/R134a Valve Core Remover/Installer (1 pc)      |



**NEW!**

## 91339 AUTOMOTIVE R12 & R134a O-RING ASSORTMENT (270 PIECE HNBR)

- 7/32" x 1/16" (5.29 x 1.78 mm) (25 pcs)
- 11 x 2 mm (15 pcs)
- 1/4" x 1/16" (6.07 x 1.78 mm) (20 pcs)
- 12 x 2 mm (15 pcs)
- 6.8 x 1.9 mm (20 pcs)
- 13.9 x 1.8 mm (10 pcs)
- 5/16" x 1/16" (7.65 x 1.78 mm) (20 pcs)
- 9/16" x 3/32" (13.95 x 2.62 mm) (10 pcs)
- 7.8 x 1.9 mm (20 pcs)
- 14 x 2 mm (10 pcs)
- 8 x 2 mm (20 pcs)
- 15 x 2 (10 pcs)
- 8.8 x 1.9 mm (20 pcs)
- 17 x 2 (10 pcs)
- 7/16" x 1/16" (10.82 x 1.78 mm) (15 pcs)
- 11/16" x 1/16" (17.17 x 1.78 mm) (10 pcs)
- 7/16" x 3/32" (10.77 x 2.62 mm) (15 pcs)
- 11/16" x 1/8" (17.04 x 3.53 mm) (10 pcs)



**Mastercool®**  
"World Class Quality"

# CHARGING ADAPTERS, REPLACEMENT GASKETS, DEPRESSORS & RETROFIT ADAPTERS

	90° ADAPTERS	REPLACEMENT	GASKET/O-RING	DEPRESSOR
A	A 90333-R	Shut-Off Valve 1/4" MFL x 1/4" FFL	90336	-
	B 90314*	1/4" MFL x 1/4" FFL	42010	42014
B	B 90340*	1/4" MFL x 1/8" FFL (High Side) Ford 1977-1980	90341	90368
	B 90354*	1/4" MFL x 3/16" FFL (High Side) GM 1976 & Later	90369	90368
C	<b>45° ADAPTERS</b>			
	C 90924	1/4" MFL x 1/4" FFL	42010	42014
	C 90927*	1/4" MFL x 3/16" FFL (High-Side)	90369	90368
D	<b>STRAIGHT ADAPTERS</b>			
	D 82272*	R134a 1/2" ACME-F x 13mm (Low-Side)	85511	-
E	E 82335	R134a Shut-Off Valve 1/2" ACME-M x 1/2" ACME-F	90330/90336	-
	E 90335-R	Shut-Off Valve 1/4" MFL x 1/4" FFL	90330/90336	-
	E 90337	Shut-Off Valve 1/4" MFL x 3/16" FFL	90330/90331	-
F	F 82634*	1/4" FFL x 1/2" ACME-M	80234	-
	F 82634-M	1/4" FFL x 1/2" ACME-M Without Valve Core	80234	-
	G 82734	14mm-M x 1/4" MFL	83341	-
G	H 90358*	1/4" MFL x 3/16" FFL (High-Side)	42010	42014
	I 90274	1/4" MFL x 1/4" FFL Swivel	42010	42014
H	I 90332**	1/4" MFL x 1/4" FFL Anti-Blowback Fitting	42010	42014
	I 90357	1/4" MFL x 3/16" FFL (High-Side) Swivel	90369	90368
I	I 91084*	1/4" MFL x 3/16" FFL (High-Side) Swivel Adapter GM 1976 & Later, Ford 1981 & Later	90369	90368
	J 90338*	GM 1991 & Later Service Adapter	90339	-
	K 90637	3/4" NPSF x 1/4" MFL Refrigeration Tank Adapter	90638	-
J	L 90633	1/4" MFL x 1/4" MFL Union	-	-
	L 82633	1/2" ACME-M x 1/2" ACME-M Union	-	-
K	<b>FLEX ADAPTERS</b>			
	M 90355*	1/4" MFL x 3/16" FFL (High-Side) GM 1976 & Later, Ford 1981 & Later	90369	90368
	M 90356*	1/4" MFL x 1/4" FFL	42010	42014
L	M 90373*	1/4" MFL x 1/8" FFL (High-Side) Ford 1977-1980	90341	90368
	M 90410	Convert 1/4 SAE Hose Into 5/16 SAE, Swivel Connection	82010	-
M	<b>ACCESS SERVICE TOOLS</b>			
	N 90296*	1/4" MFL x 1/8" MPT	-	-
	N 80296*	1/2" ACME-M x 1/8" MPT	-	-
N	* Includes Access Valve Core (0377-001) – (90-110 PSI Opening) ** Includes Check Valve Core (0332-002) – (8-12 PSI Opening)			

## RETROFIT ADAPTERS



**82357 GM HIGH FLOW ADAPTER W/ VALVE CORE & SERVICE PORT CAPS**  
GM High Flow Adapter



**INDIVIDUAL TERMINATION (BLOCK OFF CAPS)**  
81297 1/4" (7/16"-20)  
81379 3/16" (3/8"-24)

## STRAIGHT ADAPTERS W/VALVE CORE & SERVICE PORT CAPS

82274 Low side, 1/4 (7/16"- 20) x 13mm  
82332 High Side, 1/4 (7/16"- 20) x 16mm  
82358 High Side, 3/16 (3/8"- 24) x 16mm



## 90° ADAPTERS W/VALVE CORE & SERVICE PORT CAPS

82275 Low side, 1/4 (7/16"- 20) x 13mm  
82333 High Side, 1/4 (7/16"- 20) x 16mm  
82354 High Side, 3/16 (3/8"- 24) x 16mm





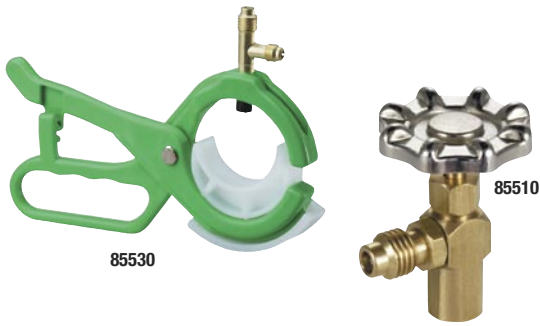

**85530 3-IN-1 SIDE MOUNT CAN TAP VALVE**

This unique design covers 2 7/8" (R134a), 2 1/2" and 2" (OIL) charge cans. Includes 1/2" ACME-M and 1/4" FL-M ports. Internal safety check valve prevents system back flow.

**85510 R134a CAN TAP VALVE - SCREW-ON MODEL**

Screw-on design for R134a ACME male can taps. Gasket assures leak proof operation. Built-in safety check. Exclusive "full grip" valve knob. 1/2" ACME-M.



**85525 R134A RECHARGE KIT**

Charge A/C systems using R134a cans with 1/2" ACME fitting



**80011 HEAVY DUTY RATCHET HOSE CUTTER**

Ratcheted action makes this cutter extremely easy to operate resulting in quick, clean cuts. Cutting blade is made of special alloy, heat treated steel for long life. Cuts all rubber hoses and PVC pipe up to 1 1/2" O.D. (Not recommended for PVC200)

**80111** Replacement blade for 80011

**80013 AUTOMOTIVE REFRIGERANT HOSE CUTTER**

Makes quick, clean cuts. Cuts rubber automotive refrigerant hoses up to 1 1/2" O.D.

**80113** Replacement blade for 80013

**ALUM BOND**

**90935**  
Aluminum Repair Kit  
(6.5 oz package)

**90934**  
Aluminum Repair Kit  
(2 oz package)

A two-component epoxy formula highly concentrated with carefully selected pure aluminum particles, modified curing agents and special high quality additives to provide maximum strength, durability and ease of application.

Alum bond is aluminum filled epoxy specially formulated for repairing condenser coils, tanks, valves, pumps, castings, water jackets, radiators, etc., where non-rusting, non-magnetic aluminum finish is desired.

**PHYSICAL PROPERTIES:**

- Hardness (Shore, ASTM D 1706): 83D
- Coefficient of Thermal Expansion: 40 x 10<sup>-6</sup> cm/cm/°C
- Compression Strength (ASTM D 695): 8600 psi (59 M Pa)
- Tensile Strength (ASTM D 638): 3500 psi (24 M Pa)
- Maximum Line Pressure (after 5 hours application time): 650 psi



**90925 CONDENSER FIN COMB**

Cleans and straightens condenser and evaporator fins. Six sided head for 8, 9, 10, 12, 14 and 15 fins per inch applications.



**93000 SPRING LOCK COUPLING TOOL SET**

Four sizes 3/8" (#6), 1/2" (#8), 5/8" (#10) and 3/4" (#12) used on Fords and Chryslers. Durable spring loaded design for long life and reliable fit.

**Set includes:** 93098 3/8" (#6) Red, 93099 1/2" (#8) Blue, 93100 5/8" (#10) Black, 93101 3/4" (#12) Beige





**POPULAR**



## 58490 UNIVERSAL R12/R134a MASTER KIT

Allows the user to service valve cores without losing the systems charge. Kit covers all R12 & R134a system valve cores for Standard, JRA, Eaton and GM Large Bore.

PATENT# 6,253,436



## VALVE CORE REMOVERS & INSTALLERS



### 81290 R134a UNIVERSAL LARGE BORE REMOVER

Used on R12/R134a Standard and JRA/EATON Large Bore R134a Valve Cores.

### 91290 UNIVERSAL VALVE CORE REMOVER

Double ended for easy replacement of Standard and GM R12 Large Bore Valve Cores.

### 90376 VALVE CORE REMOVER W/VALVE CORES FOR R12

Quickly removes valve cores. Storage area includes six replacement access valve cores.

90377 Replacement Standard Valve Cores for 90376 (6 pcs of 0377-001)



## 58531 R134a STANDARD & JRA (M6) VALVE CORE KIT

Kit covers the most popular R134a valve cores.



## 58560 R134a EATON (M8 & M10) VALVE CORE KIT

Kit covers the Eaton style R134a valve cores.



VALVE CORE REMOVERS/INSTALLERS AUTOMOTIVE/HVAC (1/4" FL)

### 91490 STANDARD VALVE CORE REMOVER/INSTALLER

Sturdy ball valve design controls refrigerant flow with 1/4 turn of the valve lever. Lever position also gives visual indication of whether valve is opened or closed.



### 91337 R12/R134a VALVE CORE REPAIR KIT

Replacement valve cores for valve core removers & installers. Consists of:

0377-001 Access Valve Core (20 pcs)

0378-001 Valve Core (10 pcs)

0531-001 R134a JRA High/Low Import Valve Core (10 pcs)

0768-001 R134a Domestic High Flow Valve Core M8 (5 pcs)

0769-001 R134a Domestic High Flow Valve Core M10 (5 pcs)

81290 R12/R134a Valve Core Remover/Installer (1 pc)

**POPULAR**

## 91046-A A/C SYSTEM FLUSH KIT

Includes flush gun, hose, canister and canister adapter. Designed to work with any light weight flushing agent which can be mixed with pressurized air. Excellent for quickly and effectively removing refrigerant oil debris during retrofitting or compressor replacement.



## 91048 FLUSH CAPTURING UNIT

Special self adjusting tool to easily recover flush material for reuse or disposal. A unique rubber bladder coupler fits over the discharge lines of the component being flushed. As flush material leaves the A/C system, it is automatically collected for reuse or disposal.

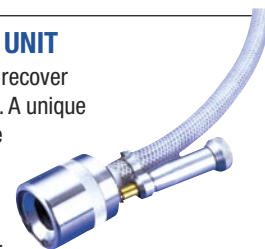



## 30 LB. AND 50 LB. DOT-APPROVED RECOVERY CYLINDERS

### Features:

- Powder coated cylinder for high gloss, durable finish
- Pre-charged cylinder provides a clean, dry interior
- 3/4" NPT opening accepts 80% fill float switch shut-off device
- Collar design for ease of handling
- Reusable and conforms to DOT-4BA400 specs and ARI guidelines
- Storage and transport of recovered refrigerant gases
- Y-valve for liquid/vapor
- AUS Approved and TC Canadian Approved
- 1/4" opening for air purge valve
- Valve & Float Switch UL Listed



Model	30 lb.						50 lb.					
	62010 without float switch	62011 with float switch	62012 with float switch & NCG Port	64010 without float switch	67010 with float switch	67011 with float switch	63010 without float switch	65010 with float switch	66010 without float switch	66011 with float switch	66012 with float switch & NCG Port	63010-AUS without float switch (Australian standard)
Connection	1/4" FL-M (7/16-20)			1/2" ACME			1/4" FL-M (7/16-20)			1/2" ACME		
Size (w x h)	9.125" x 17.52"			9.125" x 17.52"		9.125" x 17.52"	12.25" x 18.78"			12.25" x 18.78"		12.25" x 18.78"
Tare Weight	17.99 LB			17.99 LB		17.99 LB	28.71 LB			28.71 LB		28.71 LB
Standard Spec.	DOT - 4BA400			DOT - 4BA400		DOT - 4BA400	DOT - 4BA400			DOT - 4BA400		DOT - 4BA400
Nominal Water Capacity	>26.2 LB / 11.9 L			>26.2 LB / 11.9 L		>26.2 LB / 11.9 L	>47.7 LB / 21.6L			>47.7 LB / 21.6L		>47.7 LB / 21.6L
Service Pressure	400 PSI / 2.7 MPa			400 PSI / 2.7 MPa		400 PSI / 2.7 MPa	400 PSI / 2.7 MPa			400 PSI / 2.7 MPa		400 PSI / 2.7 MPa
Tank Test Pressure	800 PSI / 5.5 MPa			800 PSI / 5.5 MPa		800 PSI / 5.5 MPa	800 PSI / 5.5 MPa			800 PSI / 5.5 MPa		800 PSI / 5.5 MPa
Relief Valve Pressure	600 PSI / 4.1 MPa			600 PSI / 4.1 MPa		600 PSI / 4.1 MPa	600 PSI / 4.1 MPa			600 PSI / 4.1 MPa		600 PSI / 4.1 MPa
Air Tightness Test Pressure	400 PSI / 2.7 MPa			400 PSI / 2.7 MPa		400 PSI / 2.7 MPa	400 PSI / 2.7 MPa			400 PSI / 2.7 MPa		400 PSI / 2.7 MPa
Body Material	HP295			HP295		HP295	HP325 or HP345			HP325 or HP345		HP325 or HP345
Color	yellow/gray			blue		yellow/blue	yellow/gray			yellow/gray		white



**Mastercool®**  
"World Class Quality"

# VACUUM PUMPS

A good quality vacuum pump is an integral tool for complete A/C service. Mastercool vacuum pumps are durable and time tested. They stand up to the most grueling conditions and will provide years of reliable service. Mastercool offers a complete selection of pumps. Regardless of your service requirements, Mastercool has a model for your application.

Manifold valve isolates pump from the system when testing for leaks. Includes three inlet ports – 1/4", 3/8" SAE and 1/2" ACME on 5 and 7.5 CFM models

Gas ballast valve helps prevent oil contamination caused by high moisture

Center oil fill port is accessible from front as well as sides

Internal check valve stops oil blowout in case of accidental power loss

Includes two inlet ports – 1/4" SAE and 1/2" ACME on 1.5 CFM models

Durable lightweight die cast aluminum housing

Two-stage design allows lower pumping pressure resulting in deeper ultimate vacuum

Oil drain valve positioned at bottom of oil reservoir assures maximum drainage

Made in USA

**Ball Bearing Cartridge Design** reduces running temperatures by 30% and extends the life of the pump.

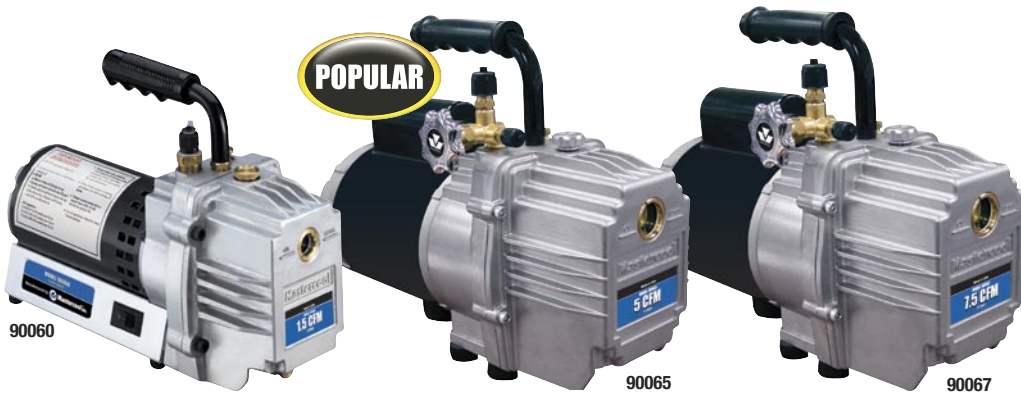

## 91200 AIR OPERATED LIGHT DUTY VACUUM PUMP

Requires 4.5 CFM/90 PSI shop air. No moving parts, no oil required, 1.3 CFM air displacement venturi type pump will pull up to 29 inches of vacuum (Hg.) at sea level. Includes 1/4" flare (R12) connection and 1/2" ACME (R134a) connection.

### 90060 1.5 CFM VACUUM PUMP (TWO STAGE)

This lightweight and easy to store vacuum pump (12lbs) is ideal for less than 3lb capacity evacuation. The inlet ports include 1/4" FL and 1/2" ACME (for automotive R134a systems).

Model #	NO OF STAGES	FREE AIR DISPLACEMENT	ULTIMATE VACUUM	PUMP MOTOR	PUMP SPEED	ELECTRICAL SPECS	SHIPPING WEIGHT
90060	2	1.5 CFM	50 MICRONS	1/6HP	3450 RPM	110V / 60HZ	12 lbs

### 90065 5 CFM VACUUM PUMP (TWO STAGE)

This model is an excellent choice for small to medium sized systems (2.5 lb to 10 lb charge capacity). This two stage pump features a manifold valve to isolate it from the system and three inlet ports: 1/4" flare, 3/8" flare and 1/2" ACME (for automotive R134a systems).

Model #	NO OF STAGES	FREE AIR DISPLACEMENT	ULTIMATE VACUUM	PUMP MOTOR	PUMP SPEED	ELECTRICAL SPECS	SHIPPING WEIGHT
90065	2	5 CFM	25 MICRONS	1/3HP	1725 RPM	110V / 60HZ	32 lbs

### 90067 7.5 CFM VACUUM PUMP (TWO STAGE)

This model is the choice for medium sized and larger systems (5 lb and above charge capacity). The 1/2 horsepower motor makes cold condition start up quick and easy. This two stage pump features a manifold valve to isolate it from the system and three inlet ports: 1/4" flare, 3/8" flare and 1/2" ACME (for automotive R134a systems).

Model #	NO OF STAGES	FREE AIR DISPLACEMENT	ULTIMATE VACUUM	PUMP MOTOR	PUMP SPEED	ELECTRICAL SPECS	SHIPPING WEIGHT
90067	2	7.5 CFM	25 MICRONS	1/2HP	1725 RPM	110V / 60HZ	34 lbs

### REPLACEMENT CARTRIDGE

1.5 CFM	
OIL CAPACITY	10 oz
REPL. CARTRIDGE	90160-R
5 CFM	
OIL CAPACITY	18 oz
REPL. CARTRIDGE	90165-R
7.5 CFM	
OIL CAPACITY	24 oz
REPL. CARTRIDGE	90167-R

### 82031 VACUUM PUMP SWIVEL ADAPTER



"T" style adapter screws onto existing 1/4" flare fitting and converts to 1/4"-FL and 1/2" ACME



## ECONOMY SERIES

- High volume fan provides cool air to motor and pump
- Vapor discharge/oil fill port, easily removable, contains internal check valve to prevent escape of liquid oil
- Non-slip cushion handle
- Includes T-fitting with 1/4" flare and 1/2" ACME ports
- Cooling fins to keep temperature cooler during extended motor operation
- Manifold valve isolates pump from the system testing for leaks. Includes 3 inlet ports, 1/4", 3/8" SAE and 1/2" ACME.
- Gas ballast valve helps prevent oil contamination caused by high moisture (90066-2V-110 & 90070-2V-110)



90059-R



90062-A

90066-A

MODEL #	NO OF STAGES	FREE AIR DISPLACEMENT	ULTIMATE VACUUM	PUMP MOTOR	PUMP SPEED	ELECTRICAL SPECS	SHIPPING WEIGHT
90059-R	1	1.5 CFM	100 MICRONS	1/6 HP	3450 RPM	110V / 60HZ	16 lbs
90062-A	1	3 CFM	75 MICRONS	1/4 HP	1720 RPM	110V / 60HZ	17 lbs
90066-A	1	6 CFM	75 MICRONS	1/4 HP	1720 RPM	110V / 60HZ	22 lbs

<b>Model</b>	<b>90066-2V-110</b>
<b>No. of Stages</b>	2
<b>Free Air Displacement</b>	6 CFM
<b>Ultimate Vacuum</b>	15 Microns
<b>Motor</b>	1/3 HP
<b>Pump Speed</b>	3440 RPM
<b>Electrical Specs</b>	110/220V 50/60 HZ
<b>Shipping Weight</b>	24.6 lbs

**POPULAR**



90066-2V-110

<b>Model</b>	<b>90070-2V-110</b>
<b>No. of Stages</b>	2
<b>Free Air Displacement</b>	10 CFM
<b>Ultimate Vacuum</b>	12 Microns
<b>Motor</b>	1/2 HP
<b>Pump Speed</b>	3440 RPM
<b>Electrical Specs</b>	110/220V 50/60 HZ
<b>Shipping Weight</b>	33 lbs.



90070-2V-110

**98061**  
**DIGITAL VACUUM GAUGE**  
in blow molded case

**98061-C**  
**DIGITAL VACUUM GAUGE**  
in clamshell

**SPECIFICATIONS:**

- Response Time: 250 mSec.
- Thermocouple Sensor Cable: 6.5 ft
- Connection Fitting: 1/4" FL-F adapter
- Operating Temperature: 32 - 120°F
- Battery Life: 36 hours
- Range: 20,000 to 1 micron
- Power: 9V DC battery
- Vacuum Units: Micron, Torr, mTorr, mmHg, mBar, Pa
- Accuracy Range\*: ATM - 1000 Microns: ±5% of reading  
1000 - 100 Microns: ±3% of reading / 100 - 1 Micron: ±1.5% of reading

\*Unit accuracy established using calibrated instrument with NIST traceability.

**OPTIONAL ACCESSORIES**

- 98061-SENSOR**  
Replacement Sensor
- 99334-110**  
110V AC/DC Adapter
- 99333**  
1/4 FL-M x 1/4 FL-M x 1/4 FL-F Tee
- 99334-220**  
220V AC/DC Adapter



**VACUUM PUMP OIL**

PART#	DESCRIPTION
90010-6	Case of Six (10 oz bottles)
90018-6	Case of Six (18 oz bottles)
90024-6	Case of Six (24 oz bottles)
90032-6	Case of Six (32 oz bottles)
90128-4	Case of Four (1 gallon bottles)



**Mastercool®**  
"World Class Quality"

**NEW!**

## 98310 WIRELESS REFRIGERANT CHARGING SCALE

## 98315 WIRELESS REFRIGERANT CHARGING SCALE WITH SOLENOID

98315 with solenoid



### FEATURES

- Wireless unit prevents unwanted tangles in wires
- Easily store the remote in the body of the platform
- Keypad provides synchronization and zeroing
- Extremely accurate weight sensor
- Magnet on remote allows easy placement on fixtures
- Battery life symbol for platform and remote constantly displayed on LCD
- Wireless signal strength indicator conveniently displays on remote
- Accepts all US & EU standard cylinders

### FUNCTIONS:

#### CHARGE PROGRAMMING:

Allows user to program desired quantities. Before charge is complete, an alarm will sound allowing ample time to turn off refrigerant supply.

#### PAUSE/CHARGE (98315 model only):

This feature allows user to stop and continue charging.

#### TANK CAPACITY PROGRAMMING:

EMPTY/FULL tank feature allows user to know the amount of refrigerant in the tank at any time.

#### REPEAT (98315 model only):

Allows user to charge previously stored amount.

### SPECIFICATIONS:

- Capacity: 243 lbs (110 kg)
- Accuracy:  $[\pm 0.01 \text{ lb} / \pm 0.005 \text{ kg}]$  or 0.1% of reading whichever is greater
- Resolution: 0.02 lb / 0.01 kg
- Automatic Shut-Off: After 20 minutes
- Operating Temperature: 32°F to 120°F (0°C to 49°C)
- Battery Life: approximately 20 hours
- 31 cm Platform

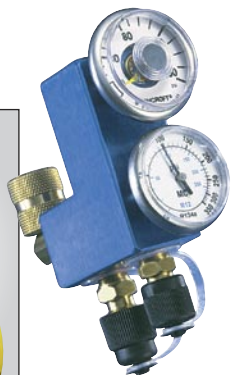

## 98100 AIR CONTENT ANALYZER

When an A/C system leaks, refrigerant is lost and air enters the system. Your refrigerant recycler cannot tell the difference between refrigerant and air - it recycles both from partially filled systems. You end up with an unknown quantity of efficiency robbing air in your supply tank. Excess actual pressure in your supply tank, indicates the pressure of air also called "non-condensable gases" or NCG's. When you release the excess pressure, you are releasing air. The result is purer refrigerant, which will work more efficiently.

The Mastercool Air Content Analyzer is more accurate than most automatic purging systems. It can be left on your supply tank for regular monitoring or it can be removed to check all your tanks. (R12/R134a)



## ELECTRONIC TANK HEATER BLANKET

The Mastercool Refrigerant Tank Heater Blanket speeds up recharging time.

- Assures total discharge of refrigerant from 30 lb and 50 lb tanks. Heats tanks to 125°F resulting in maximum pressure of 185 psi for R134a and 170 psi for R12.
- Quick working 300W heater element
- An excellent complement to all Mastercool Refrigerant Scales

98250 110V

98250-220 220V



## 98210-A ACCU-CHARGE II

Mastercool's ACCU-CHARGE II is the most advanced electronic refrigerant scale in the market today. Constructed with a rugged aluminum cast body, the ACCU-CHARGE II now offers programming capabilities.

### FUNCTIONS:

**CHARGE PROGRAMMING:** Allows user to program desired quantities. Before charge is complete, an alarm will sound allowing user ample time to turn off refrigerant supply.

**TANK CAPACITY PROGRAMMING:** Allows user to know the amount of refrigerant that is left in the tank at any time.

**REPEAT:** Allows user to charge previously stored amount.

### SPECIFICATIONS:

- Capacity: 240 lbs (110 kg)
- Accuracy:  $\pm 0.01$  kg  
 $\pm 0.16$  oz  
 $\pm 0.01$  lb } or 0.1% of reading  
(whichever is greater)
- Resolution: 0.01 kg / 0.02 lb
- 3 hrs Auto Off Function
- Operating Temperature is 32 to 120°F (0 to 49°C)
- Battery Life (approximately 40 hrs)
- Works w/110 or 220V Transformer (not available)
- 9 x 9" (22 x 22 cm) Platform



## 98211-A ACCU-CHARGE III CERTIFIED REFRIGERANT SCALE (OIML & CE Approved, Legal for Trade)



**CHARGE PROGRAMMING:** Allows user to program desired quantities. Before charge is complete, an alarm will sound allowing user ample time to turn off refrigerant supply.

**PAUSE/CHARGE:** (Using the 98230 Charging Solenoid Module)

**TANK CAPACITY PROGRAMMING:** Allows user to know the amount of refrigerant that is left in the tank at any time.

**REPEAT:** Allows user to charge previously stored amount.

### SPECIFICATIONS:

- Complies with European (OIML) Standards
- Capacity: 110 lbs (50 kg)
- Accuracy:  $\pm 50$  g
- Resolution: 0.10 lbs (0.05 kg)
- 3 hrs AUTO OFF Function
- Operating Temperature is 32 to 120°F (0 to 49°C)
- Battery Life (approximately 40 hrs)
- 9 x 9" (22 x 22 cm) Platform

OIML  
CE

## 98230 CHARGING SOLENOID MODULE

The 98230 Charging Solenoid Module turns the 98210-A ACCU-CHARGE II & 98211-A ACCU-CHARGE III into Automatic Programmable Scales!

This module allows the user to control the exact amount of refrigerant transferring to and from the A/C System. The compact design is battery powered (9V), light-weight, portable and works with all types of refrigerant. 98230 includes a short hose for tank connection, USB cord and 1/4" FL - 1/2" ACME adapters.



**Mastercool®**  
"World Class Quality"

# TWIN TURBO

REFRIGERANT RECOVERY MACHINE

**69300** 115V - 60 HZ

Mastercool's newest addition to the recovery machine lineup takes the reliability of the 69000 series machines and enhances those features to allow for maximum recovery capacity while at the same time decreasing size and weight. The design of the new double piston compressor and cooling by the largest fan and condenser in the market makes the 69300 series the most complete solution to your recovery needs!



69300

**Liquid Recovery (In) lb/min**  
• Temperature: 79 to 82°F / Refrigerant: R134a

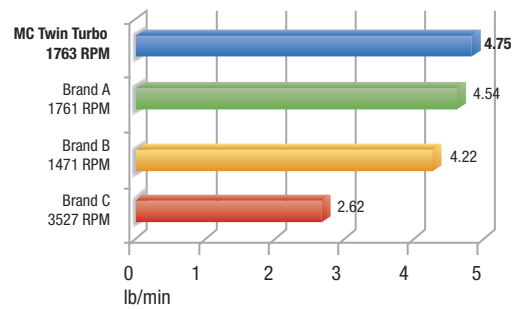

**Vapor Recovery (In) lb/min**  
• Temperature: 79 to 82°F / Refrigerant: R134a

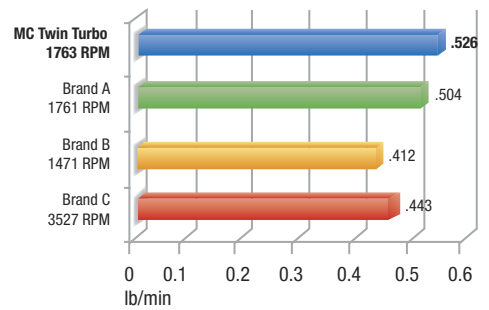

**Push Pull lb/min**  
• Temperature: 79 to 82°F / Refrigerant: R134a

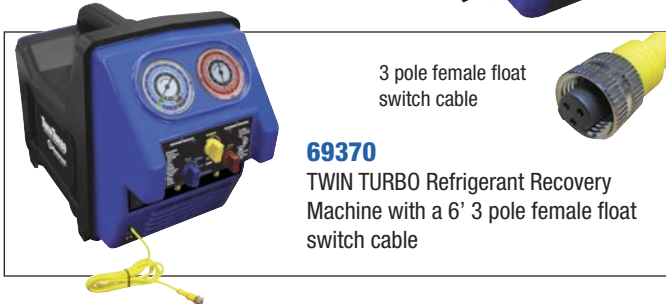
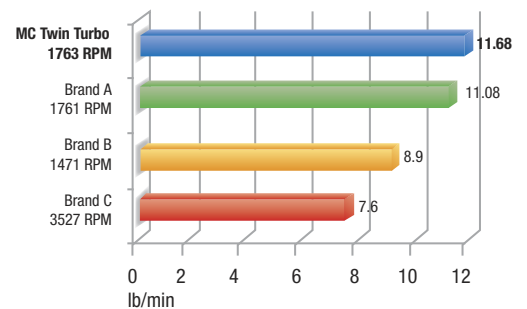

3 pole female float switch cable

**69370**  
TWIN TURBO Refrigerant Recovery Machine with a 6' 3 pole female float switch cable

**69360** 115V - 60HZ

This unit offers all the same functions and features as the 69300 in addition it has an oil separation module, filter dryer and sight glass.

**69500-DR** Replacement Filter Dryer for 69360 and 69100



**FEATURES & BENEFITS:**

- Revolutionary double piston oil-less compressor
- Safety high pressure switch
- Simple internal structure for field service
- Largest volume recovery rate in market
- For use with all refrigerants including R410A
- Injection molded high density polyethylene case for maximum durability
- Front cover has bumper guards built in to reduce damage to the control knobs

**SPECIFICATIONS:**

- 1/2 hp oil less compressor
- Recovery Rate:

R134a	R22
• Direct vapor up to .526 lb/min	• Direct vapor up to .63 lb/min
• Direct liquid up to 4.75 lb/min	• Direct liquid up to 7.56 lb/min
• Push pull up to 11.68 lb/min	• Push pull up to 18.3 lb/min

- Operating Temperature: 32 to 122°F
- Weight: 28.3 lbs
- Dimensions: 418" (l) x 10" (w) x 14" (h)
- Case Material is HDPE (High Density Polyethylene)
- Compatible refrigerants: All CFC, HCFC, and HFC's



## 69000 REFRIGERANT RECOVERY SYSTEM (115V-60Hz)

These recovery systems are compact, lightweight and work with all refrigerants. They're ideal for commercial, residential or industrial appliance applications. Our recovery systems offer a state-of-the-art 1/2 HP oil-less compressor with a built-in high volume cooling fan. This innovative design delivers maximum cooling efficiency which keeps the compressor working at high capacities in even the hottest climates. The compressor is also protected by an automatic low pressure cut-off switch that shuts off the unit once the recovery is complete. This AUTO SHUT-OFF feature eliminates the risk of compressor failure and reduces the user's need to monitor the entire recovery system. All of our recovery systems offer our color-coded gauges with pressure readings in PSI, BAR and MPa. Our stainless steel ball valve designed manifold, controls the flow smoothly and quickly with only a 1/4 turn. With all of this protected by a reinforced hard plastic case, Mastercool's recovery systems will meet all your refrigerant recovery needs.

### FEATURES:

- High performance oil-less compressor
- High volume cooling fan design
- Automatic low pressure cut-off switch
- Liquid compatible head-valve system
- Safety high pressure cut-off switch
- Fully reinforced hard plastic casing
- Made in USA

### SPECIFICATIONS:

- 1/2 HP oil-less compressor
- Recovery Rate
  - Direct vapor up to .44 lb/min
  - Direct liquid up to 2.62 lb/min
  - Push pull up to 12 lb/min
- Operating temp. range: 32 to 122°F
- Weight: 38 lbs / Dim.: 17" L x 10" W x 12" H
- Refrigerants: CFC's, HCFC's, HFC's



## 69100 COMPLETE A/C RECOVERY SYSTEM (115V-60Hz)

The 69100 Professional Recovery System is compact, lightweight and works with all refrigerants. It offers a state of the art 1/2 hp oil-less compressor with a built-in high volume cooling fan. This innovative design delivers maximum cooling efficiency which keeps the compressor working at high capacities in even the warmest climates. The compressor is protected by an automatic low pressure cut-off switch that shuts off the unit once the recovery is complete. This auto shut-off feature eliminates the risk of compressor failure and reduces the user's need to monitor the entire recovery process. The 69100 also includes an oil separator and filter dryer to cleanse the refrigerant during the recovery process.

The Mastercool Recovery System offers our newest color-coded gauges with pressure readings in PSI, BAR and MPa. The stainless steel ball valve designed manifold controls the refrigerant flow smoothly and quickly with only a 1/4 turn. All of the internal components have been arranged and isolated to ensure a smooth and quiet performance. With all of this protected by a reinforced hard plastic case, Mastercool's Recovery System will meet all of your refrigerant needs.

### FEATURES & BENEFITS:

- High performance oil-less compressor
- High volume cooling fan design
- Automatic low pressure cut-off switch
- Liquid compatible head-valve system
- Safety high pressure cut-off switch
- Fully reinforced hard plastic casing
- Made in USA



## Design Certified to Meet SAE J2810

## 69110 AUTOMOTIVE A/C RECOVERY SYSTEM

- Includes Recovery Unit, 30 lb DOT Tank, a 60" Yellow Service Hose, 72" Blue and Red Conversion Hoses, UL Approved High and Low Side R134a Manual Couplers and Oil Purge Bottle
- Designed to meet SAE J2810 and works with all refrigerants.
- Recovers and removes oil from refrigerant.
- All internal components have been arranged and isolated to ensure smooth and quiet performance.
- State of the art 1/2 hp oil-less compressor with built-in high volume cooling fan.
- Delivers maximum cooling efficiency, keeping compressor working at high capacities even in warmest climates.
- Compressor protected by automatic low pressure cut-off switch eliminating risk of compressor failure and reducing need to monitor entire recovery process.
- Stainless steel ball valve design manifold controls refrigerant flow smoothly and quickly with only 1/4 turn.
- Gauges provide pressure readings in PSI, BAR and MPa.

### SPECIFICATIONS:

- Refrigerant R134a
- High Side Design Pressure 500 psig
- Low Side Design Pressure 174 psig
- 115 Volts AC
- 1 PH, 60 HZ., 8.6 Amps, 1.25 S/F
- Service Factor 10.75 AMP
- Made in USA

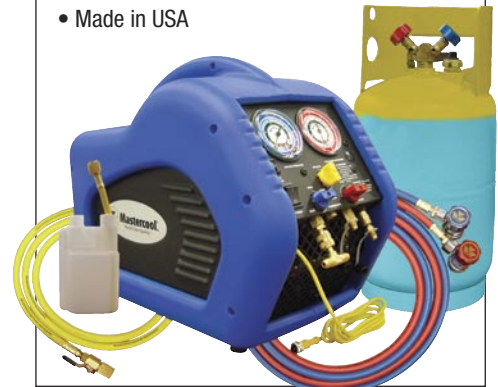

### SPECIFICATIONS:

- 1/2 HP oil-less compressor
- Recovery Rate
  - Direct vapor up to .44 lb/min
  - Direct liquid up to 2.62 lb/min
  - Push pull up to 12 lb/min
- Operating temp. range: 32 to 122°F
- Weight: 38 lbs / Dim.: 17" L x 10" W x 12" H
- Refrigerants: all



**Mastercool®**  
"World Class Quality"



## 69500 RECOVERYMATE

**Speed up the recovery process!** Remove unwanted moisture and separate oil from Recovered Refrigerant. (Use with any Recovery Machine.)

### SPECIFICATIONS:

- Lightweight and easy to carry
- 4-Way Ball Valve Manifold controls the flow smoothly and quickly with only 1/4 turn
- Large capacity oil separator
- High Performance Dryer eliminates moisture from recovered refrigerant
- Extra large sight glass monitors refrigerant flow and changes color when a dryer change is necessary
- Rugged carrying case can stand on its own or be mounted on a wall or bench
- Length: 15" / Width: 4" / Height: 17"
- Weight: 5.5 kg (12.25 lbs)

## PORTABLE ELECTRONIC CHARGING STATIONS

A lightweight, durable, steel frame cart that contains all the necessary tools to quickly and conveniently charge the A/C system. No need for different sized charging cylinders with Mastercool's rugged die cast electronic scale. Simply place the refrigerant cylinder on the scale and charge.

### FEATURES:

- A rugged, lightweight steel cart with wheels and convenient storage pocket for scale and hoses allows this portable charging station to be taken almost anywhere
- 240 lb capacity scale with long lasting 9V battery (60 hrs)
- Deep micron, rotary vane vacuum pumps.
- Extruded aluminum manifold with long lasting valve design

### 2 STAGE PORTABLE ELECTRONIC CHARGING STATION

- Large 3 1/8" gauges make it easy to read the pressure and temperature scales
- Deep micron, rotary vane vacuum pumps Available in 1.5, 5 and 7.5 CFM
- Includes set of 72" hoses

Also available:

- Refrigerant tank heater blanket #98250 and #98250-220
- D.O.T. cylinder #62010-R12 w/o float

\* R134a Automotive Service Couplers not included

\* 220V units with metric gauges are available. Please specify.

VACUUM PUMP	1.5 CFM 110V	5 CFM 110V	7.5 CFM 110V
MANIFOLD			
2 Way Alum Block	<b>91580</b>	<b>91585</b>	<b>91587</b>
4 Way Alum Block	<b>91581</b>	<b>91586</b>	<b>91588</b>



## MOBILE ELECTRONIC CHARGING STATION

Keeping the same ideals in mind as the Portable Electronic Charging Station, Mastercool introduces its new mobile unit directed towards the garage technician. With an enlarged carry cart and larger wheels, this new unit can get around the shop with the greatest of ease!

VACUUM PUMP	1.5 CFM
MANIFOLD	110V
2 Way Alum Block	<b>91680</b>
4 Way Alum Block	<b>91681</b>

VACUUM PUMP	5 CFM
MANIFOLD	110V
2 Way Alum Block	<b>91685</b>
4 Way Alum Block	<b>91686</b>

VACUUM PUMP	7.5 CFM
MANIFOLD	110V
2 Way Alum Block	<b>91687</b>
4 Way Alum Block	<b>91688</b>



### SINGLE STAGE PORTABLE ELECTRONIC CHARGING STATION

- 2 1/2" gauges
- Deep micron, rotary vane vacuum pumps. Available in 1.5, 3 and 6 CFM

Also available:

- Refrigerant tank heater blanket #98250 and #98250-220

<b>91580-A</b>	<b>91580-B</b>	<b>91585-B</b>
R134a 2-way Manifold	R134a 2-way Manifold	R134a 2-way Manifold
1.5 CFM Single Stage Vacuum Pump	3 CFM Single Stage Vacuum Pump	6 CFM Single Stage Vacuum Pump
Electronic Charging Scale	Electronic Charging Scale	Electronic Charging Scale
Manual Couplers	Manual Couplers	Manual Couplers
Set of Hoses	Set of Hoses	Set of Hoses



**69788-A AUTOMATIC R134a R/R/R    69789 FULLY AUTOMATIC R134a R/R/R    69789-H R134a & HYBRID R/R/R**

**69788-A Specifications**

- Type of Refrigerant: R134a
- Service Procedure: Automatic/Programmable or Manual
- Voltage: 115 V / 60 Hz
- Scale Resolution: .02 lb (10 g)
- Working Temperature: 59/120°F (11/49°C)
- Filter System: 2 filters for humidity
- Vacuum Pump: 6 CFM (100 litre/min)
- Compressor: Hermetically sealed, 12cc, high pressure
- Recovery Cylinder: Internally mounted 30 lb. DOT tank
- Hoses: 96" (250 cm)
- Couplers: Manual
- Bottle Temperature Sensor: Integrated
- Bottle Heater: Standard Equipment
- Dimensions: 40.25" (h) x 22.75" (w) x 20" (d)  
(102 x 58 x 51 cm)
- Weight: 157 lbs (71 kg)

**69789/69789-H Specifications**

- Type of refrigerant: R134a
- Service Procedure: Fully automatic or manual
- Voltage: 115 V / 60 Hz
- Scale Resolution: .02 lb (10 g)
- Oil Scale Resolution: .01 lb (5 g)
- Working Temperature Range: 59/120°F (11/49°C)
- Filter System: 2 filters for humidity
- Vacuum Pump: 6 CFM (100 litre/min) capacity, (.001 psi) 0.1 mbar vacuum level
- Compressor: Hermetically sealed, 12cc, high pressure
- Recovery Speed: .66 lb/min (300 g/min) in liquid phase
- Recovery Cylinder: 30 lb (22 litres), refillable
- Hoses: 96" (250 cm)
- Couplers: Manual
- Thermal Printer: Standard Equipment
- Pressure Gauges: Class 1
- Bottle Temperature Sensor: Integrated
- Bottle Heater: Standard Equipment
- Dimensions: 41.3" (h) x 23.6" (w) x 21.6" (d) (105 x 60 x 55 cm)
- Weight: 176 lbs (80 kg)



**69789-H Features Refrigerant Oil Flush System**



**69788-FLTRPK**  
Filter pack for  
69788-A, 69789, 69789-H



	69788-A	69789	69789-H
• Large Display: 4.8" (w) x 1.7" (h) (122mm (w) x 42mm (h))	x		
• Large Graphic Display: 4.3" (w) x 2.4" (h) (110mm (w) x 60mm (h))		x	x
• Quality Performance Year after Year	x	x	x
• Design Certified for Compliance with SAE J2788 : New A/C systems are smaller. Machines must charge within .5 oz and recover 95% of the refrigerant.	x	x	x
• Automatic/Programmable or Manual : Can be programmed to complete a continuous recovery/recycle, vacuum and recharge. Can also be set to run each operation individually.	x	x	x
• Includes Refrigerant Capacity Database (over 1000 vehicles) : Includes refrigerant capacities for US and Import makes and models from 1995 to 2012. Capable of database upgrades as well.	x	x	x
• Auto Vacuum Leak Test : Can be programmed to perform a vacuum leak test and will inform the technician of possible leaks.	x	x	x
• Auto Oil Discharge : Oil is automatically discharged during the recovery process. If oil is present, it will drain into a graduated container clearly displaying the amount of oil that was removed.	x	x	x
• Auto Air Purge: Automatically purges non-condensable gas (NCG) from the storage tank during recovery.	x	x	x
• Auto Filter Alarm : The machine's LCD and alarm will warn that a filter change is required.	x	x	x
• Compact Footprint : The machine's compact design makes it easy to maneuver and requires minimal shop space.	x	x	x
• Full Tank Alarm : Notifies operator when tank is full.	x	x	x
• Low Refrigerant Alarm : Notifies operator when refrigerant is low.	x	x	x
• Automatic Oil Injection : With electronic scale to protect the contents against contact and ambient humidity.		x	x
• Thermal Printer : For a complete, detailed report.		x	x
• Fully Integrated Real "Loop," Flushes Service Hoses Only by Refrigerant Circulation : Flushing eliminates the risk that residues of different (non-insulating) oils may be injected into the A/C system, jeopardizing its safety and operation.			x
• High Voltage Protection			x
• Used on all Hybrid and R134a Vehicles			x



**Mastercool®**  
"World Class Quality"



## 69134-A REFRIGERANT IDENTIFIER FOR R134a

- Keeps Equipment Safe
- Prevents Contamination
- Detects Air Contamination

The Refrigerant Identifier helps confirm the presence and quality of R134a refrigerant in vehicle air conditioning systems. This process will help avoid potential damage from refrigerant contamination. This unit delivers quick and precise refrigerant analysis in a rugged, compact and portable package. The refrigerant identifier automatically provides step-by-step indication of the gas sampling process.

### SPECIFICATIONS:

- Weight: 0.8 kg
- Refrigerant Detected: R134a (Tetrafluoroethane)
- Accuracy: PASS/FAIL - 95% Pure R134a
- Power Requirements: 12 VDC
- User Interface: Membrane type with visual indicators and function key
- Calibration Method: Manual pump aspirator
- Minimum Input Pressure: 1.38 Bar (20 Psig)
- Maximum Input Pressure: 20.70 Bar (300 Psig)
- Storage Temperature: -10° to 50°C
- Operating Temperature: 10 to 45°C
- Construction Material: Molded ABS housing/molded rubber sleeve

Mastercool's new nitrogen regulator is specifically designed to meet the specifications of HVAC/R and automotive A/C systems. This single stage nitrogen regulator is used to test systems for leaks when they do not contain refrigerant.

- 1/4" SAE flare outlet port, with control valve, to keep pressure on the regulator at all times
- T-Handle for ease of pressure adjustment
- 2 1/2" gauges with guards
- High pressure gauge 4400 psig (300 bar)
- Low pressure gauge 1000 psig (70 bar)
- Kits come with leak testing gauge and charging hose, packaged in a blow molded case



Directive 97/23/EC



## 53001 NITROGEN PRESSURE REGULATOR

- CGA580 (US) Standard
- 1/4 FL-M outlet connection

## 53010-AUT PRESSURE TESTING REGULATOR KIT

- 53001 Nitrogen Pressure Regulator
  - CGA580 (US) Standard
  - 1/4 FL-M outlet connection
- 48" Yellow Charging Hose (47482)
- Leak Testing Adapter (53042)
- High Side Standard R134a
  - 1/4" FL-M x 13mm Economy Coupler (66434-R)
- Blow molded case (53000-PB)

### OPTIONAL ACCESSORIES

PART #	DESCRIPTION
82834	High Side Manual R134a 14mm-F x 16mm Coupler
90413	R410a Straight Adapter 1/4" FL-M x 5/16" Swivel-F
53042	Leak Testing Adapter
53000-42	Leak Testing Gauge
53000-70	Low Pressure Regulator Gauge
53000-300	High Pressure Regulator Gauge
47482	48" Yellow Charging Hose
93254-E	Black Gauge Guard
53000-W	Teflon Washer



## COMPACT UV LEAK LOCATOR KITS

Leading the way in UV LEAK DETECTION, Mastercool offers a variety of compact UV Leak Locator Kits. Each kit offers a powerful inspection lamp, a "Refillable" or "Cartridge Type" Dye Injector and accessories. All kits are packaged in a clamshell or custom molded carrying case.

### 53100

- High Intensity, 12V/100 Watt, Swivel Head Light (53012)
- Refillable 2 oz Dye Injector (53123)
- 2 oz Concentrated Universal A/C Fluorescent Dye (25 Application) (53625)
- 4 oz Dye Remover (5334)
- 25 Service Information Labels
- UV Enhancing Safety Glasses

### 53100-C

Same as 53100, but with Replaceable 2 oz Dye Cartridge (53223) (25 Applications)

### 53500

- High Intensity, 12V/50 Watt, Mini Light (53312)
- Refillable 2 oz Dye Injector (53123)
- 2 oz Concentrated Universal A/C Fluorescent Dye (25 Applications) (53625)
- 4 oz Dye Remover
- 25 Service Information Labels
- UV Enhancing Safety Glasses

### 53500-C

Same as 53500, but with Replaceable 2 oz Dye Cartridge (25 Applications)

### 53451-110

- Rechargeable UV light, batteries, rechargeable batteries, battery holder, 110V charger (53518-UV)
- Refillable 2 oz Dye Injector (53123)
- 2 oz Concentrated Universal A/C Fluorescent Dye (25 Application) (53625)
- 4 oz Dye Remover (53314)
- 25 Service Information Labels
- UV Enhancing Safety Glasses

### 53451-C-110

Same as 53451-C-110, but with Replaceable 2 oz Dye Cartridge (25 Applications)



53500

53100-C



53451-C-110



53351

### 53351

- High Intensity, 12V/50 Watt, Mini Light (53312)
- Replaceable 1 oz (10 application) Dye Cartridge (53809)
- A/C Connection Hose w/R134a Coupler
- R12 Adapter
- 1 oz OIL/ATF/Gas and Diesel Fluorescent Dye
- 1 oz Engine Coolant Dye
- 4 oz Dye Remover
- 25 Service Information Labels
- UV Enhancing Safety Glasses



53580



53585

### 53580

- MACH IV Flexible LED UV Light (53515)
- 1 oz Dye Injector (53809)
- Replaceable 1 oz Dye Cartridge (10 Application)
- Low-Side Hose w/R134a Coupler
- R12 Adapter
- 10 Service Info. Labels
- UV Enhancing Safety Glasses
- 2 - CR2 Lithium 3V Batteries

### 53585

Same as above, but w/1 oz OIL/ATF/Gas (53610) & Diesel Fluorescent Dye and 1 oz (30 ml) Engine Coolant Fluorescent Dye (53609)



**Mastercool®**  
"World Class Quality"



53518-UV

53517-UV

53512-UV



### 53518-UV RECHARGEABLE UV FLASHLIGHT

- Twist the handle to zoom the UV light in or out
- AAA battery holder provides backup power to flashlight (3 AAA batteries included)
- Battery Life: 3 to 5 hours continuous leak detection
- Includes safety glasses

#### SPECIFICATIONS:

- High Intensity LED
- 154 - 170  $\mu\text{W}/\text{cm}^2$  which is compatible to a 50 watt UV flashlight
- Battery: Lithium Li-Ion, full discharge and cut-off discharge of 4.2V and 2.75V
- 2 Illumination Modes: super bright and battery conservation mode
- 53518-UV includes 110V charger

### 53512-UV MINI UV FLASHLIGHT

- 12 LED Bulb UV Illumination
- Battery Life: 5 hours continuous leak detection
- Includes safety glasses

### 53517-UV COMPACT UV FLASHLIGHT

- 17 LED Bulb UV Illumination
- Battery Life: 4 hours continuous leak detection
- Includes safety glasses

#### 53512-UV & 53517-UV SPECIFICATIONS:

- Aluminum body with Type III anodized finish
- Easy grip texture
- 25,000 hour bulb life
- 3 AAA batteries

### 53012 UV SWIVEL HEAD LIGHT (12V/100 WATTS)

- 180° Swivel Heads Get Into Tight Places
- Instant ON
- Heavy Duty Metal Construction
- Includes UV Enhancing Safety Glasses



### 53312 UV MINI LIGHT (12V/50 WATTS)

- High Intensity
- 16 ft. Cord
- Compact & Lightweight
- Includes UV Enhancing Safety Glasses
- Instant ON



### 53515 MACH IV FLEXIBLE UV LIGHT

- The Mach IV flexible UV light has **4 TRUE UV LEDS** delivering a brilliant fluorescent glow.
- Gets into tight areas easily.
  - Rugged Ergonomic Grip
  - Includes UV Enhancing Safety Glasses.

PATENT NO. 6,647,761



LIGHT PART#	LIGHT BULB PART#	LENS PART#
53012	53012-B	53012-L
53312	53312-B	53312-L
53515	53515-B	-

### ACCESSORIES

53314 DYE REMOVER - 4oz (120ml)

53315 SERVICE LABELS -

25 per pack, bright yellow label indicating that the system has been charged with UV Dye

92398 UV ENHANCING SAFETY GLASSES -

This is a must for protection against ultraviolet light during leak detection.

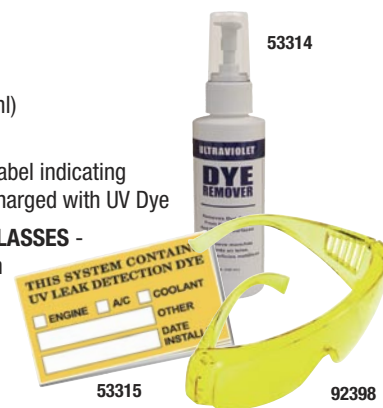

53315

92398



**OIL INJECTORS**

Excellent method for adding refrigerant oil or large amounts of UV leak detection dye to the A/C system. Add oil by allowing vacuum to pull it in after the evacuation process, or use refrigerant to push it in using the recharge system. Rugged all metal 2 oz canister. Available in standard or "easy connect" design. The standard models use a needle style valve attached between the manifold gauge set or charging equipment and A/C hose. The "easy connect" models use a ball valve design attached directly onto the end of the A/C hose. Model 82374 includes a low-side coupler on the outlet hose. Model 92376 includes auto shut-off valve on the outside hose.

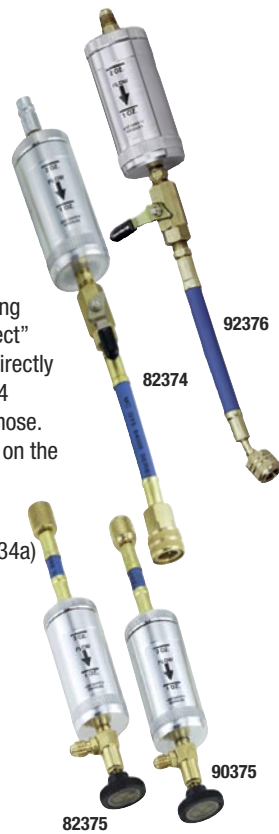

**STANDARD**

**82375** 1/2" ACME-M x 1/2" ACME-F (R134a)

**90375** 1/4" FFL x 1/4" MFL

**EASY CONNECT**

**82374** 13mm-M x 13mm-F Low-Side Coupler (R134a)

**92376** 1/4" FFL x 1/4" MFL

**ULTRAVIOLET DYES**

**STANDARD UNIVERSAL A/C DYES**

**92699** **Standard Universal Dye** - Pack 1/4 oz - 1 Application  
Six 1/4 oz Packs (6 pcs)

**92708** **Standard Universal Dye**  
8 oz Bottle - 32 Applications

**92732** **Standard Universal Dye**  
32 oz Bottle - 128 Applications

**CONCENTRATED UNIVERSAL DYES**

**53825** **Universal Dye Cartridge**  
Replaceable Cartridge - 25 Applications

**53810** **Concentrated Dye Cartridge**  
Replaceable Cartridge - 10 Applications

**53625** **Universal Dye**  
2 oz Bottle - 25 Applications



**COMPRESSOR OILS**

Maximum protection with excellent thermal & oxidative stability. Moisture tolerant. OEM approved.

**53826** **PAG 100 Oil** (2 oz cartridge)

**53827** **Ester Oil** (2 oz cartridge)

**92709** **PAG 100 Oil** (8 oz bottle)

**92710** **Ester Oil** (8 oz bottle)

**92711** **PAG 100 Oil** (32 oz bottle)

**92712** **Ester Oil** (32 oz bottle)



**REFILLABLE UNIVERSAL DYE/OIL INJECTOR**

To inject the oil or dye, simply connect the injector to the low side of the A/C system and twist the handle until you reach the desired amount. The injector hose comes complete with a R134a coupler and auto shut-off valve adapter for 1/4" FL systems.

**53123** **REFILLABLE UNIVERSAL DYE INJECTOR**  
with 2 oz Bottle of Concentrated A/C Dye (25 Apps)

**53123-A** **REFILLABLE UNIVERSAL DYE/OIL INJECTOR** (w/o dye)

**53134** **REFILLABLE DYE INJECTOR**  
with (R134a 13 mm Connection) and 2 oz Bottle of Concentrated A/C Dye (25 Applications)

**53322** **REFILLABLE DYE INJECTOR**  
with (1/4" Auto Shut-off Valve Connection) and 2 oz Bottle of Concentrated A/C Dye (25 Apps)

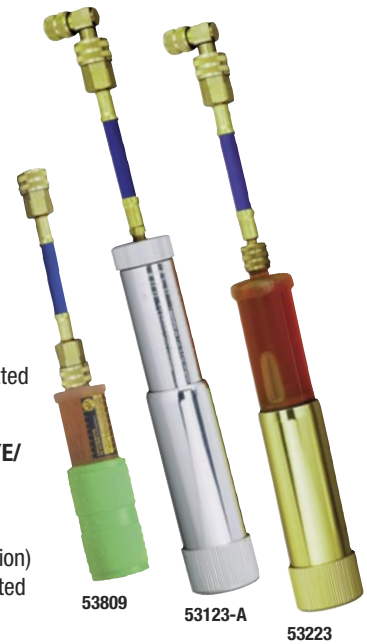

**53809 MINI DYE INJECTOR**

"Cartridge Type" Dye Injector (10 Applications) Concentrated Dye.

**53223 "CARTRIDGE TYPE" UNIVERSAL DYE/OIL INJECTOR**

Adding dye with the 53223 is fast and easy, simply connect the injector to the low side of the A/C system and twist the handle to the next application line. The replaceable cartridge provides 25 applications of universal dye that is compatible with R12/22/502 and R134a systems. The injector hose comes complete with a R134a coupler and auto shut-off valve adapter for 1/4" FL systems.



**FLUORESCENT DYE**

**53609** **ENGINE COOLANT FLUORESCENT DYE** (1 oz. bottle)

- 1 oz for 1 vehicle application per 16 quarts of fluid

**53610** **OIL/AFT/GAS FLUORESCENT DYE** (1 oz. bottle)

- Engine Oil (Gas & Diesel)  
1 vehicle application per 4-5 quarts of oil
- Automatic Transmission Fluid  
1 vehicle application per 4-5 quarts of fluid
- Gasoline & Diesel Fuel  
1 vehicle application per 2 gallons of fuel



**Mastercool®**  
"World Class Quality"

The **55200 "INSPECTOR"** and **55100** offer revolutionary new features and state of the art micro processing technology. The new design sensor delivers an accurate and instantaneous response. Both units come in a heavy duty custom molded carrying case and meet SAE J1627 and CE conformity.

### 55200 / 55100 FEATURES / SPECIFICATIONS

- Digital Signal Micro Processor
- Auto Release Feature
- Keypad Control
- Detects All Halogenated Refrigerants
- Battery Test Feature
- Power Supply (2 "C" Batteries)
- Meets SAE J1627 / CE Conformity
- Flexible 16" Probe
- Variable Frequency Audible Alarm
- Includes Custom Molded Carrying Case

## 55100 ELECTRONIC LEAK DETECTOR

The 55100 offers an accurate and reliable solution to Electronic Leak Detection.

### SPECIFIC FEATURES:

- 3 Levels Of Sensitivity (5 Levels Of Detection)
- Visual Leak Level Indicator
- Detects Leaks As Small As 3 gr (1/10 oz) Per Year
- Detects All Refrigerants, CFC'S, HCFC'S, HFC'S

### 55100-SEN

Sensor Tip for 55100, 55200, 55300 & 55400



## 55200 "INSPECTOR" 2 IN 1 ELECTRONIC / UV LEAK DETECTOR

This revolutionary design allows the user to perform Electronic and UV Leak Detection all with one tool. The "INSPECTOR" offers six levels of sensitivity (15 levels of detection) with a tri-colored LED indicator. This allows the "INSPECTOR" to pin-point leaks as small as 1/10 oz per year. The ultra bright UV light is built into the end of the probe allowing easy access into tight areas. Incorporating both electronic and UV technology into one unit insures that even the toughest leaks can be found. **PATENT# 6,647,761**

### SPECIFIC FEATURES

- 6 Levels Of Sensitivity (15 Levels Of Detection)
- Detects Leaks As Small As 1/10 oz Per Year
- Detects All Refrigerants, CFC'S, HCFC'S, HFC'S
- Ultra Bright UV/Blue LED Light
- UV Safety Glasses
- Tricolored Visual Leak Level Indicator
- Mute Function

**53515-B** LED Bulb for 55200, 55300 & 55400



### 55310 COMPLETE ELECTRONIC & UV LEAK DETECTION KIT

This kit offers the "INSPECTOR" along with our UV Dye Injection System. Our cartridge type dye

injector is fast and easy to use. Just twist the handle to inject the appropriate amount of dye.

### SPECIFIC FEATURES

- 55200 "INSPECTOR" Electronic Leak Detector
- UV Dye Injector w/10 Application Dye Cartridge
- Dye Injector Connection Hose w/R12 Adapter
- Dye Cleaner & UV Safety Glasses
- Comes In A Custom Molded Carrying Case

**55300 - Same as 55310** (with 25 application Dye Cartridge)

### 55400 COMPLETE ELECTRONIC & UV LEAK DETECTION KIT

This kit offers the "INSPECTOR" along with our UV Dye Injection System. Our refillable dye injector is fast and easy to use. Just twist the handle to inject the appropriate amount of dye.

### SPECIFIC FEATURES

- 55200 "INSPECTOR" Electronic Leak Detector
- Refillable Dye Injector
- Dye Injector Connection Hose w/R12 Adapter
- 2 oz Bottle of Concentrated Universal Dye
- UV Safety Glasses & Dye Cleaner
- Comes In A Custom Molded Carrying Case



Tricolored Visual Leak Level Indicator

Inject the A/C System with Dye! The UV Light Button will illuminate the Leak!

Mute Function

Use Reset to Ignore Current Level of Leak and look for Higher Level of Concentration





## ELECTRONIC LEAK DETECTOR W/HEATED SENSOR

Mastercool broadens its line by introducing its Heated Sensor Electronic Leak Detector. The HEATED SENSOR technology delivers fast and accurate results while eliminating non-refrigerant false alarms. The flexible 15" probe has a patented UV Blue Light built into the tip allowing dual UV and Electronic Leak Detection. **PATENT# 6,647,761**

**55500** Electronic Leak Detector w/110V Battery Charger

**55500-220** Electronic Leak Detector w/220V Battery Charger

### SPECIFICATIONS:

- Operating Temp: 32-125°F
- Power Supply: 2 C-Size 1.5V Ni-MH Battery
- Battery Life: 8 hrs per cycle (1000 cycles)
- Warm-Up Time: 25 Seconds
- Probe/Core Length: 15"
- Dimension: 7 x 7"
- Weight: 1.10 lbs
- Ultimate Sensitivity: 1/10 oz per year

### FEATURES:

- Six Sensitivity Levels
- Automatic Warm Up
- Reset Function
- Dual-colored Visual LED Leak Size Display
- Blue UV LED Light
- Rechargeable Ni-MH Battery
- Low Battery Indicator
- High Volume Pump
- Meets and Exceeds SAE J1627
- Made in USA
- Detects all Refrigerants (CFC's, HCFC's, HFC's)

Part#	Description
<b>53515-B</b>	LED Bulb for 55500
<b>55500-SEN</b>	Replacement Sensor



## COMBUSTIBLE GAS LEAK DETECTOR

Mastercool introduces its hand-held combustible gas leak detectors. Offering the most advanced sensor technology with a state-of-the-art microprocessor, these units detect leaks fast and accurately. The flexible 15" probe has a bright LED light built into the tip for easy viewing in hard to reach locations. The membrane switch panel offers easy one touch control and operation. Each of the six levels of sensitivity has an audible alarm and visual indicator to identify leak activity. These units include the newest rechargeable Ni-MH battery (nearly double the power of existing Ni-Cad batteries) and comes in a custom molded case. **PATENT# 6,647,761**

**55750** Combustible Gas Leak Detector w/110V Battery Charger

**55750-220** Combustible Gas Leak Detector w/220V Battery Charger

### SPECIFICATIONS:

- Operating Temp: 32-125°F
- Power Supply: 2 C-Size 1.5V Ni-MH Battery
- Battery Life: 8 hrs per cycle (1000 cycles)
- Warm-Up Time: 25 seconds
- Probe/Core Length: 15"
- Dimension: 7 X 7"
- Weight: 1.10 lbs
- Ultimate Sensitivity: 50 – 1000 ppm

### FEATURES:

- Six Sensitivity Levels
- Reset Function
- Automatic Warm Up
- Bright LED Light
- Audible Leak Alarm & Visual Leak Size Indicator
- Rechargeable Ni-MH Battery
- Low Battery Indicator
- Custom Molded Carrying Case
- Made in USA



### DETECTS:

Acetone, Acetylene, Ammonia, Benzene, Butane, Butanol, Chlorine, Ethane, Ethanol, Gasoline, Hexane, Hydrogen, Hydrogen Sulfide, Isobutane, Methane (natural gas), Methanol, Methyl Acetate, Methyl Chloride, Methyl Ether, Naptha, N-Butane, Pentane, Propane, Propanol, Sulfur Dioxide and Trichloroethane



**Mastercool®**  
"World Class Quality"

**POPULAR**



**NEW**  
**COLOR SCREEN**



## 52224-A INFRARED THERMOMETER W/LASER

The 52224-A offers laser targeting accuracy, enhanced backlit LCD Display and an expanded temperature range. The compact design is simple to use and easy to store.

**Non-Contact Temperature Range:** -58 to 932°F (-50 to 500°C)

**Field of View:** 12 : 1

**Display Illumination:** Backlit LCD Color Display

**Target Indicator:** Single Laser Spot

**Emissivity:** 0.98

**Resolution:** 0.5°F / 0.5°C

**Accuracy:** ±2°C (4°F) or ±2% of reading

**Response Time:** 0.5 seconds

**Power Off:** Automatic after 15 seconds

**Battery Life:** Approximately 180 hours

**Included Accessories:** 2 AAA batteries, instruction manual, plastic molded carrying case



**NEW**  
**COLOR SCREEN**



## 52224-C INFRARED THERMOMETER WITH DUAL LASER

Features both infrared and dual laser technologies.

**Non-Contact Temperature Range:** -76 to 1022°F (-60 to 550°C)

**Field of View:** 12 : 1

**Display Illumination:** Backlit LCD Color Display

**Target Indicator:** Dual Laser Spot

**Emissivity:** 0.95

**Resolution:** 0.1°F / 0.1°C

**Accuracy:** ±2°C (4°F) or ±2% of reading

**Response Time:** 1 second

**Power Off:** Automatic after 15 seconds

**Battery Life:** Approximately 180 hours

**Included Accessories:** 2 AAA batteries, instruction manual, plastic molded carrying case



3 ft. (1m) Wire  
Thermocouple Included

## 52225-A DUAL TEMP PLUS INFRARED THERMOMETER

Features both infrared and contact thermometer technologies. Includes programmable HI/LO alarms and Lock Mode to capture temperature readings. The contact function offers a built-in K type jack and wire thermocouple.

**Non-Contact Temperature Range:** -76 to 1400°F (-60 to 760°C)

**Thermocouple Temperature Range:** -83 to 1999°F (-64 to 1400°C)

**Field of View:** 30 : 1

**Display Illumination:** Backlit LCD display

**Target Indicator:** Single Laser Spot

**Emissivity:** 0.10 (10E) to 1.0 (100E)

**Resolution:** 0.1°F / 0.1°C

**Modes:** MIN, MAX, DIFF & AVG

**Accuracy:** ±2% of reading or 2°C (4°F)

whichever is greater

**Thermocouple Probe Accuracy:** ±1% of reading

or 1°C (1.8°F) whichever is greater

**Response Time:** 1 second

**Power Off:** Automatic after 15 seconds

**Battery Life:** Approximately 180 hours

**Included Accessories:** 2 AAA batteries, 1m thermocouple probe, instruction manual, plastic molded carrying case

**Optional Accessories:** 3m Wire Thermocouple Probe, Piercing Penetration Probe, Surface Probe, Air Probe



CALL 973 252-9119



CLICK [www.mastercool.com](http://www.mastercool.com)



## 52225-B ULTRA TEMP DUAL LASER THERMOMETER

Features both infrared and contact thermometer technologies. Includes programmable HI/LO alarms, and Lock Mode to capture temperature readings. The built-in K type jack offers optional contact functions. Illuminates working area with built-in LED light.

**Non-Contact Temperature Range:** -76 to 1832°F (-60 to 1000°C)

**Thermocouple Temperature Range:** -83 to 1999°F (-64 to 1400°C)

**Field of View:** 50 : 1

**Display Illumination:** Backlit LCD display

**Target Indicator:** Dual Laser Spot

**Emissivity:** 0.10 (10E) to 1.0 (100E)

**Resolution:** 0.1°F / 0.1°C

**Modes:** MIN, MAX, DIFF & AVG

**Accuracy:** ±2% of reading or 2°C (4°F) whichever is greater

**Response Time:** 1 second

**Power Off:** Automatic after 15 seconds

**Battery Life:** Approximately 180 hours

**Included Accessories:** 2 AAA batteries, instruction manual, plastic molded carrying case

**Optional Accessories:** 1m, 3m Wire Thermocouple Probes, Piercing Penetration Probe, Surface Probe, Air Probe, Removable Magnetic Base



## OPTIONAL THERMOCOUPLE PROBES

**52331** WIRE PROBE - 3 FT (1M)

**52332** WIRE PROBE - 10 FT (3M)

**52333** PIERCING PENETRATION PROBE W/COIL CORD

**52334** SURFACE PROBE W/COIL CORD

**52335** AIR PROBE W/COIL CORD

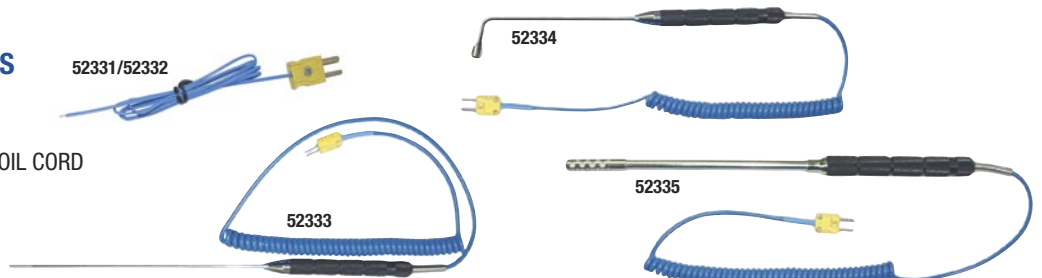

All thermometers include pocket holder and clip.

### POCKET ANALOG DESIGNS

Item#	Dial Size	Temperature Scale
52220	1"	0 to 220°F
52161	1 3/8"	-40 to 160°F
91120	1 3/4"	0 to 220°F

### POCKET DIGITAL DESIGN

Item#	Dial Size	Temperature Scale
52223-A	1"	-58 to 302°F

Battery operated (1.5V, life of 5000 hours), on/off and auto shut-off after 10 minutes.

## 52226 DUAL TEMP INFRARED/PROBE THERMOMETER

The 52226 Dual Temp Thermometer offers both infrared and contact probe technologies.

- Infrared Temp Range: -67 to 428°F (-55 to 220°C)
- Probe Temp Range: -67 to 626°F (-55 to 330°C)
- Field of View Ratio 1 : 1
- Adjustable Emissivity
- Lock Mode for hands free scanning
- Minimum/Maximum capture mode
- Contact Probe locks safely on the side of the unit

## 52227 POCKET INFRARED THERMOMETER

The 52227 Pocket Infrared Thermometer offers accurate non-contact temperature measurement in a compact and easy to use size.

- Temp Range: -67 to 428°F (-55 to 220°C)
- Field of View Ratio 1 : 1
- Adjustable Emissivity
- Backlit LCD Display
- Minimum/Maximum capture mode



**Mastercool®**  
"World Class Quality"

## 71475 UNIVERSAL HYDRAULIC FLARING TOOL SET

This kit fabricates Push Connect 1/4, 5/16 and 3/8"; GM Fuel Line Flare, Brake Lines and Transmission 5/16 and 3/8"; Flare/Double Flare 3/16, 1/4, 5/16, 3/8 and 1/2"; Metric Bubble Flare 4.75, 6, 8, and 10mm. Comes in a custom molded box. **PATENT# 5,782,128 / 6,324,884**

<b>71201</b>	Hydra-flare Yoke & Pump Assembly	<b>71097-01</b>	45° Flaring Cone
<b>Push-Connect Adapters</b>		<b>Push-Connect Die Sets</b>	
<b>71204</b>	1/4" Adapter	<b>71214</b>	1/4" Die Set
<b>71205</b>	5/16" Adapter	<b>71215</b>	5/16" Die Set
<b>71206</b>	3/8" Adapter	<b>71216</b>	3/8" Die Set
<b>GM Fuel Line Adapters</b>		<b>GM Fuel Line Die Sets</b>	
<b>71405</b>	5/16" Adapter	<b>71415</b>	5/16" Die Set
<b>71406</b>	3/8" Adapter	<b>71416</b>	3/8" Die Set
<b>45° &amp; Double Flaring Adapters</b>		<b>45° &amp; Double Flaring Die Sets</b>	
<b>71097-03</b>	3/16" Adapter	<b>71097-13</b>	3/16" Die Set
<b>71097-04</b>	1/4" Adapter	<b>71097-14</b>	1/4" Die Set
<b>71097-05</b>	5/16" Adapter	<b>71097-15</b>	5/16" Die Set
<b>71097-06</b>	3/8" Adapter	<b>71097-16</b>	3/8" Die Set
<b>71097-08</b>	1/2" Adapter	<b>71097-18</b>	1/2" Die Set
<b>Metric Bubble Flaring Adapters</b>		<b>Metric Bubble Flaring Die Sets</b>	
<b>71475-4M</b>	4.75mm Adapter	<b>71475-14M</b>	4.75mm Die Set
<b>71475-6M</b>	6mm Adapter	<b>71475-16M</b>	6mm Die Set
<b>71475-8M</b>	8mm Adapter	<b>71475-18M</b>	8mm Die Set
<b>71475-10M</b>	10mm Adapter	<b>71475-110M</b>	10mm Die Set
<b>71475-PB</b>	Custom Molded Plastic Box for 71475		
<b>71201-001A-REPK</b> Repair Kit for 71475, 71480, 71300, 71400, 71450			



Push Connect  
GM Fuel Line  
45° Double Flare  
Metric Bubble Flare

## 71197 DOUBLE FLARING ADAPTERS AND DIES FOR HYDRA-FLARE YOKE AND PUMP ASSEMBLY

Includes: 71097-03, 71097-04, 71097-05, 71097-06, 71097-08, 71097-13, 71097-14, 71097-15, 71097-16, 71097-18, 71097-01



GM Transmission Cooling Line

## 71124 PUSH CONNECT ADAPTERS AND DIES FOR HYDRA-FLARE YOKE AND PUMP ASSEMBLY

Includes: 71204, 71205, 71206, 71214, 71215, 71216

## 71099-TC 3/8" GM TRANSMISSION COOLING LINE DIE AND ADAPTER SET

Set includes **71099-06** adapter and **71099-16** die set. To be used with 71475 hydraulic pump assembly.

## 71144 GM FUEL LINE ADAPTERS AND DIES FOR HYDRA-FLARE YOKE AND PUMP ASSEMBLY

Includes: 71405, 71406, 71415, 71416



## 71098 37° FLARING & DOUBLE FLARING ADAPTER SET

- Dies: 3/16, 1/4, 5/16, 3/8 and 1/2"
- Double Flare Adapters: 3/16, 1/4, 5/16, 3/8 and 1/2"
- 37° Cone



**71480 37° FLARING AND DOUBLE FLARING HYDRAULIC TOOL KIT**

This kit fabricates factory style 37° and 37° double flare found on aviation and specialty automotive applications. The handheld hydraulic pump operates easily with all steal and light stainless tubing. Includes: 3/16, 1/4, 5/16, 3/8 and 1/2" dies 3/16, 1/4, 5/16, 3/8 and 1/2" double flare adapters and 37° Cone



<b>71201</b>	Hydra-flare Yoke & Pump Assembly	<b>71098-01</b>	37° Cone
<b>37° Double Flaring Adapters &amp; Die Sets</b>			
<b>71098-03</b>	3/16" Double Flare Adapter	<b>71098-13</b>	3/16" Double Flare Die Set
<b>71097-04</b>	1/4" Double Flare Adapter	<b>71098-14</b>	1/4" Double Flare Die Set
<b>71097-05</b>	5/16" Double Flare Adapter	<b>71098-15</b>	5/16" Double Flare Die Set
<b>71097-06</b>	3/8" Double Flare Adapter	<b>71098-16</b>	3/8" Double Flare Die Set
<b>71097-08</b>	1/2" Double Flare Adapter	<b>71098-18</b>	1/2" Double Flare Die Set



71450  
45° Double Flare  
Metric Bubble Flare

**71450 DOUBLE FLARE & METRIC BUBBLE FLARING TOOL SET**

This kit fabricates flare/double flare 3/16, 1/4, 5/16, 3/8 and 1/2"; and metric bubble flare 4.75, 6, 8 and 10mm. Comes in a custom molded carrying case and includes:

<b>71201</b>	Hydra-flare Yoke & Pump Assembly	<b>71097-01</b>	45° Flaring Cone
<b>71450-PB</b>	Custom Molded Carrying Case		
<b>45° &amp; Double Flaring Adapters and Die Sets:</b>		<b>Metric Bubble Flaring Adapters and Die Sets:</b>	
<b>71097-03</b>	3/16" Adapter	<b>71475-4M</b>	4.75mm Adapter
<b>71097-04</b>	1/4" Adapter	<b>71475-6M</b>	6mm Adapter
<b>71097-05</b>	5/16" Adapter	<b>71475-8M</b>	8mm Adapter
<b>71097-06</b>	3/8" Adapter	<b>71475-10M</b>	10mm Adapter
<b>71097-08</b>	1/2" Adapter	<b>71475-14M</b>	4.75mm Die Set
<b>71097-13</b>	3/16" Die Set	<b>71475-16M</b>	6mm Die Set
<b>71097-14</b>	1/4" Die Set	<b>71475-18M</b>	8mm Die Set
<b>71097-15</b>	5/16" Die Set	<b>71475-110M</b>	10mm Die Set
<b>71097-16</b>	3/8" Die Set		
<b>71097-18</b>	1/2" Die Set		



71400  
GM Fuel Line

**71400 GM FUEL LINE FLARING KIT**

This kit fabricates the special flares found on most GM fuel lines and some GM truck power steering pump return lines (5/16"). Kit comes in a custom molded carrying case and includes:

<b>71201</b>	Hydra-flare Yoke & Pump Assembly
<b>GM Fuel Line Adapters and Die Sets:</b>	
<b>71405</b>	5/16" Adapter
<b>71415</b>	5/16" Die Set
<b>71406</b>	3/8" Adapter
<b>71416</b>	3/8" Die Set
<b>71200-PB</b>	Custom Molded Carrying Case



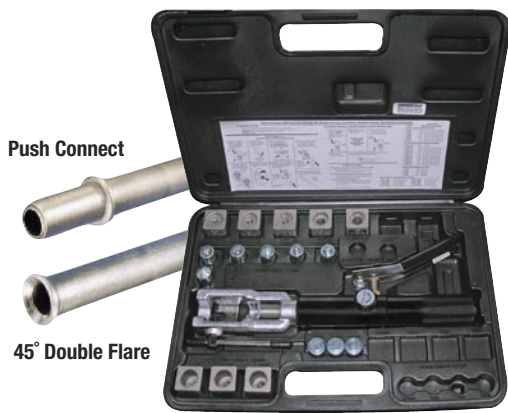

Push Connect

45° Double Flare

## 71300 PUSH-CONNECT, 45° & DOUBLE FLARING SET WITH “HYDRA-FLARE”

Fabricates “production quality” flares quickly and easily with hand held convenience. Flaring die sets for five sizes: 3/16, 1/4, 5/16, 3/8 and 1/2” O.D. tubing; five double flaring adapters cover 3/16, 1/4, 5/16, 3/8 and 1/2” O.D. tubing. Set includes:

<b>71201</b>	Hydra-flare Yoke & Pump Assembly	<b>71097-01</b>	45° Flaring Cone
--------------	----------------------------------	-----------------	------------------

### Push-Connect Adapters and Die Sets:

<b>71204</b>	1/4” Adapter	<b>71214</b>	1/4” Die Set
<b>71205</b>	5/16” Adapter	<b>71215</b>	5/16” Die Set
<b>71206</b>	3/8” Adapter	<b>71216</b>	3/8” Die Set

### 45° & Double Flaring Adapters and Die Sets:

<b>71097-03</b>	3/16” Adapter	<b>71097-13</b>	3/16” Die Set
<b>71097-04</b>	1/4” Adapter	<b>71097-14</b>	1/4” Die Set
<b>71097-05</b>	5/16” Adapter	<b>71097-15</b>	5/16” Die Set
<b>71097-06</b>	3/8” Adapter	<b>71097-16</b>	3/8” Die Set
<b>71097-08</b>	1/2” Adapter	<b>71097-18</b>	1/2” Die Set



Metric  
Bubble  
Flare

## 71100 METRIC BUBBLE FLARING TOOL SET

Fashions International Standards Organization (I.S.O.) bubble flare found on European, Japanese and some domestic model brake lines. Flares without removing brake lines from a vehicle. Includes hardened steel bar and carrying case. Set includes: Adapters for 4.75, 6, 8 and 10mm O.D. tubing. Also available:

**71101** Set of four bubble flaring adapters for 4.75, 6, 8 and 10mm O.D. tubing.



45° Double  
Flare

## 70092 45° FLARING, DOUBLE FLARING & CUTTING TOOL SET

Includes heavy duty tube cutter **70033** for 1/8 to 1 1/8” O.D. tubing; standard 45° flaring tool **70051** flares 7 sizes: 3/16, 1/4, 5/16, 3/8, 7/16, 1/2 and 5/8” O.D. tubing; five double flaring adapters **70192** cover 3/16, 1/4, 5/16, 3/8 and 1/2” O.D. tubing. Also available:

**70097** Same as 70092, less 70033 tube cutter

**70192** Set of 5 double flaring adapters for 3/16, 1/4, 5/16, 3/8 and 1/2” O.D. tubing.

**70092-M** Metric Flaring, Double Flaring & Cutting Tool Set Flares 7 metric sizes: 4, 6, 8, 10, 12, 15 and 16mm O.D. tubing.

**70192-M** Metric Double Flaring Adapter Set Covers 4.75, 5, 6, 8 and 10mm O.D. tubing.

**70097-M** Same as 70092-M, less 70033 tube cutter.



Fabricating A/C Hoses Just Got Easier With The...

**71500 HYDRA-KRIMP**

Mastercool's Patented "Hydra - Krimp" makes crimping barbed and beaded fittings as easy as 1 - 2 - 3! The lightweight hand-held hydraulic press is very portable and ideal for shop and field applications. The kit comes with a complete set of dies covering hose sizes #6, #8, #10, #12 and reduced barrier #6, #8, #10 and #12. The dies snap quickly into the press fixture requiring no pins or screws. Kit comes in a custom molded case and includes:

Part#	Description
71500-001A	Hydra - Krimp Pump
71500-001B	Hydra - Krimp Yoke
71500-001C	Complete Die Set Assembly (7 pc. set)
71500-6	Die Set - #6 (5/16") Die Set - #8 (13/32") Reduced Barrier
71500-8	Die Set - #8 (13/32")
71500-10	Die Set - #10 (1/2")
71500-12	Die Set - #12 (5/8")
71500-6SRB	Die Set - #6 (5/16") Reduced Barrier
71500-10SRB	Die Set - #10 (1/2") Reduced Barrier
71500-12SRB	Die Set - #12 (5/8") Reduced Barrier
71500-PB	Custom Molded Box
71500-REPAIRKT	Repair Kit for 71500

PATENT# 6,324,884



**71550 A/C HOSE CRIMPER**

The 71550 is our "manual style" A/C hose crimper. The dies snap quickly into place requiring no pins or screws. The unit can be easily mounted to a bench using the holding fixture or held securely in a vice. This kit comes with a complete set of dies covering standard hose sizes #6, #8, #10 and #12.

\*Optional reduced barrier sizes are available.

Part#	Description
71550-001	Yoke Assembly
71550-002	Arbor Assembly
71550-003	Holding Fixture Assembly
71500-6	Die Set - #6 (5/16")
71500-8	Die Set - #8 (13/32")
71500-10	Die Set - #10 (1/2")
71500-12	Die Set - #12 (5/8")
71550-PB	Custom Molded Carrying Case

PATENT# 6,324,884



**Mastercool®**  
"World Class Quality"

## BALL BEARING CUTTERS

Mastercool's EZ Tube Cutters offer the latest "Reduced Friction" technology! Our reduced friction design incorporates ball bearings into the cutter wheel, tube rollers and a control knob. Reducing the resistance in these high friction areas allows the cutter to roll fast and easy as it slices through the tube. The "Reduced Friction" design is sure to save time and reduce fatigue!

- 72029** "REDUCED FRICTION" TUBE CUTTER for 1/8 to 1 1/8" (3-28mm)
- 72035** "REDUCED FRICTION" TUBE CUTTER for 1/4 to 1 1/2" (6-38mm)
- 72030** REPLACEMENT CUTTING WHEEL for 72029
- 72034** REPLACEMENT CUTTING WHEEL for 72035

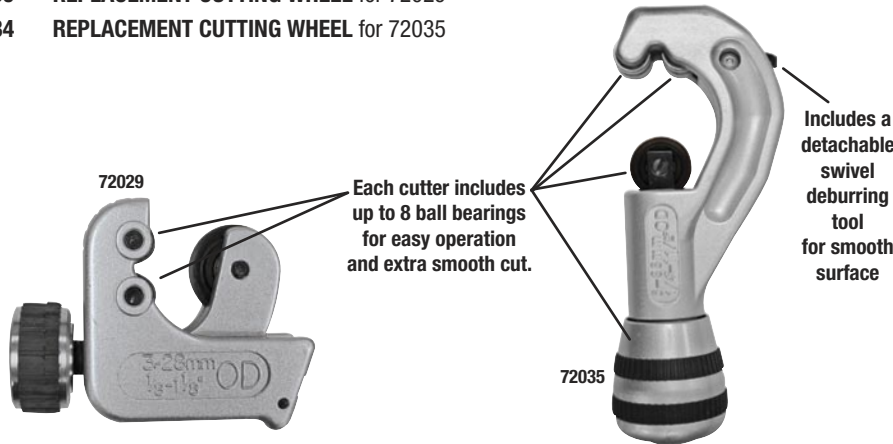

## TUBE CUTTERS

MASTERCool tube cutters are lightweight yet durable. Carbide steel cutting wheels work with hard and soft copper, aluminum, brass, thin wall steel and stainless steel. All cutters feature rollers with flare cut-off grooves to salvage as much old tubing material as possible.



- 70027** MINI TUBE CUTTER for 1/8 to 5/8" (3-16mm) O.D. Tubing (1/8 to 1/2" Nominal)
- 70029** MINI TUBE CUTTER for 3/8 to 1 1/8" (4-28mm) O.D. Tubing (1/4 to 1" Nominal)
- 70033** HEAVY DUTY TUBE CUTTER for 1/8 to 1 1/8" (4-28mm) O.D. Tubing (1/4 to 1" Nominal)

- 70035** HEAVY DUTY TUBE CUTTER for 1/4 to 1 5/8" (6-40mm) (1/4 to 1 1/2" Nominal)
- 70037** SLIDING RATCHET TUBE CUTTER for 1/4 to 2 5/8" (6-67mm) O.D. Tubing (1/4 to 2 3/4" Nominal), Triple Chrome Plated
- 70038** SLIDING RATCHET TUBE CUTTER for 1/4 to 3 1/2" (6-89mm) O.D. Tubing (1/4 to 1 1/2" Nominal)

## RATCHET STYLE TUBE CUTTER

- 70030** When you don't have swing room, ratchet action allows cutting all the way around the tubing easy (1/4 to 7/8" O.D. Tubing)
- 70031** (5/16 to 1 1/8" O.D. Tubing)

## 80021 PLUMBERS TYPE MINI CUTTER

Designed for applications with limited working space. Cuts soft copper, aluminum and thin wall steel tubing. Tube Cutter for 1/8 to 7/8" (4-22mm) O.D. Tubing. (1/8 to 3/4" nom.)

- 80121** Spare Cutting Wheel for 80021





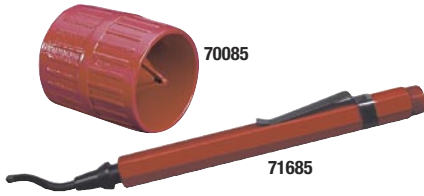

**INNER-OUTER REAMERS**

- 70085** Inner/Outer Reamer for 3/16 to 1 1/2" O.D. Tubing.
- 71685** Designed to remove inner burrs easily. Full metal grip. Includes one spare tungsten blade for long use.
- 71686-2** Two spare blades for 71685 (2 pcs).

**REPLACEMENT CUTTER WHEELS**

- 70028** Replacement Cutting Wheels for 70027 (10 pcs).
- 70034** Replacement Cutting Wheels for 70029, 70033, 70035 and 70037 (10 pcs + 1 holding screw).
- 70128** Carbide Cutting Wheel & Screw Set for 70027 includes: 2 Spare Cutting Wheels and 1 Holding Screw.
- 70134** Carbide Cutting Wheel and Screw Set for 70029, 70035, and 70037. Includes: 2 Spare Cutting Wheels and 1 Holding Screw.
- 70138** Replacement Cutting Wheel for 70038 (1 per pkg.) Cut Hard and Soft Copper, Aluminum, Brass, Thin Wall Steel and Stainless Steel.
- 70237** PVC Cutting Wheel for 70037. Cuts PVC and ABS.
- 70238** Oversize PVC Cutting Wheel for 70038. Wheel is 1 5/8" Diameter. Cuts PVC and ABS.

**TUBE CONSTRICTOR WHEEL**

**70233** Used with 70033 or 70035.

**SPRING STYLE TUBE BENDERS**

Economical and effective tools for bending soft copper or aluminum tubing without kinks. Special nickel plated, spring steel is flared on one end for quick tube insertion. Each tool bends one size.

MODEL#	SIZE	LENGTH
70071	1/4"	10"
70072	5/16"	10"
70073	3/8"	10"
70074	1/2"	12"
70075	5/8"	14"
70077	3/4"	14"



**70069-A 4-IN-1 LEVER STYLE TUBE BENDER**

Complete 180° bend all metal multi-purpose tube bender for 3/16, 1/4, 5/16 and 3/8" O.D. Tubing.



**70076 SPRING STYLE TUBE BENDER SET**

Set of 5 spring benders for 1/4, 5/16, 3/8, 1/2 and 5/8" O.D. tubing.



**RATCHET WRENCHES**

- 70081** Steel forged wrench with reversible ratchet. 9/16", 1/2" hex, 1/4" and 3/16" square.
- 70082** Compact chrome plated wrench specially designed for use in hard to reach places. 1/4, 3/8, 3/16 and 5/16" square ratchet.



**Mastercool®**  
"World Class Quality"



## 91292 MASTER SANDEN COMPRESSOR SERVICE TOOL SET

All specialized tools necessary to service seal, clutch and clutch bearing on Sanden 505, 507, 508, 510 and 575. Complete with tool box and instructions.

Contains:

- |              |                                     |              |                                       |
|--------------|-------------------------------------|--------------|---------------------------------------|
| <b>90381</b> | Holding Fixture & Hardware          | <b>90923</b> | Internal Retaining Ring Plier         |
| <b>90383</b> | Internal Snap Ring Plier            | <b>90926</b> | Clutch Installing Pilot               |
| <b>90385</b> | York Seal Remover/Installer         | <b>91047</b> | Metal Tool Box                        |
| <b>90412</b> | O-Ring Seal Sleeve Remover          | <b>91052</b> | Clutch Plate Installer                |
| <b>90414</b> | Seal Seat Remover                   | <b>91059</b> | Bearing & Pulley Installer            |
| <b>90443</b> | Pulley Bearing Remover/Driver       | <b>91073</b> | Sanden 505 Seal Seat Remover          |
| <b>90451</b> | Pulley Arbor                        | <b>91074</b> | Sanden 505 Bearing & Pulley Installer |
| <b>90457</b> | Puller Body                         |              |                                       |
| <b>90901</b> | Clutch Holder                       | <b>91075</b> | Sanden 505 Seal Protector Sleeve      |
| <b>90902</b> | Clutch Plate Puller                 | <b>91076</b> | Pulley & Clutch Remover Jaws          |
| <b>90903</b> | External Retainer Remover/Installer | <b>91077</b> | Shaft Protector Pilot                 |
| <b>90905</b> | Seal Retainer Remover/Installer     | <b>91146</b> | Feeler Gauge Set                      |
| <b>90906</b> | Seal Remover & Installer            |              |                                       |
| <b>90907</b> | Seal Protector Sleeve               |              |                                       |
| <b>90910</b> | Clutch Plate Installer              |              |                                       |
| <b>90916</b> | Oil Level Checker                   |              |                                       |
| <b>90917</b> | Pulley & Clutch Remover Jaws        |              |                                       |
| <b>90922</b> | Pilot Studs                         |              |                                       |

**All tools available individually.**

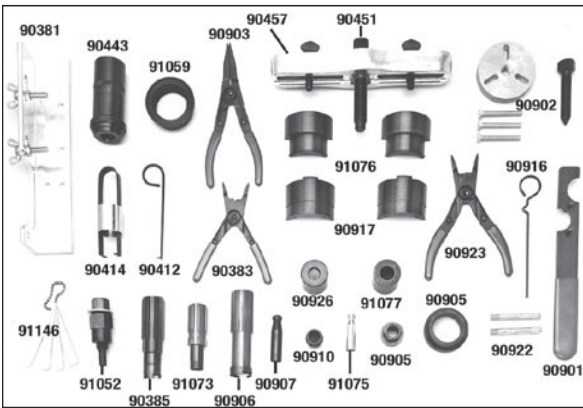

## 91295 MASTER IMPORT COMPRESSOR CLUTCH, SEAL & BEARING SERVICE TOOL SET

Includes all the tools necessary to replace seals, clutches and clutch bearing on Diesel Kiki (Zexel), Hitachi, Mitsubishi, Nippondenso, Seiko-Seiki and Sanden 505, 507, 508, 510, 575, 708 and 709. Complete with tool box and instructions.

Contains:

- |              |                                       |              |   |
|--------------|---------------------------------------|--------------|---|
| <b>90385</b> | York Seal Remover & Installer         | <b>91091</b> | Mitsubishi Seal Remover & Installer       |
| <b>90386</b> | Compressor Holding Fixture            | <b>91134</b> | Diesel Kiki Clutch Puller Thrust Pin      |
| <b>90390</b> | Diesel Kiki Bearing Drive             | <b>91135</b> | Diesel Kiki Retainer Ring Installer       |
| <b>90396</b> | Diesel Kiki Clutch Installer          | <b>91136</b> | Mitsubishi/Sanden Clutch Plate Remover    |
| <b>90443</b> | Pulley Bearing Remover & Installer    | <b>91137</b> | Diesel Kiki Pulley Puller Pilot           |
| <b>90451</b> | Pulley Arbor                          | <b>91138</b> | Diesel Kiki Seal Remover & Installer      |
| <b>90457</b> | Puller Body                           | <b>91139</b> | Diesel Kiki Seal Seat Remover & Installer |
| <b>90499</b> | Universal Clutch Holding Tool         | <b>91146</b> | Universal Feeler Gauge Set                |
| <b>90906</b> | Seal Remover & Installer              | <b>91171</b> | Mitsubishi Seal Remover Lock Sleeve       |
| <b>90907</b> | Seal Protector Sleeve                 |              |   |
| <b>90910</b> | Clutch Plate Installer                | <b>91183</b> | Air Conditioning Manual                   |
| <b>91011</b> | Nippondenso Clutch Plate Remover      | <b>91311</b> | Hitachi Spanner Plug Remover & Installer  |
| <b>91047</b> | Metal Tool Box                        |              |   |
| <b>91044</b> | Diesel Kiki Nut Remover               |              |   |
| <b>91045</b> | Diesel Kiki Plate Remover             |              |   |
| <b>91052</b> | Sanden Plate Installer                |              |   |
| <b>91058</b> | Pulley Removal Jaws                   |              |   |
| <b>91059</b> | Bearing & Pulley Installer            |              |   |
| <b>91060</b> | Seal Seat Remover                     |              |   |
| <b>91061</b> | Seal Seat Installer                   |              |   |
| <b>91073</b> | Sanden 505 Seal Seat Remover          |              |   |
| <b>91074</b> | Sanden 505 Bearing & Pulley Installer |              |   |
| <b>91075</b> | Sanden 505 Seal Protector Sleeve      |              |   |
| <b>91090</b> | Mitsubishi Seal Seat Remover          |              |   |

**All tools available individually.**





## 91269 SEAL SERVICE KIT

General Motors A6, R4, Late DA6, HR-6, V5, 6 Pole R4 Seal Set Includes the tools needed to replace seals on GM compressors from the early sixties through the current model year as well as Tecumseh HR-980.

Contains:

- |              |                                      |              |  |
|--------------|--------------------------------------|--------------|--|
| <b>90383</b> | Internal Snap Ring Pliers            | <b>90412</b> | O-Ring Seal Sleeve Remover             |
| <b>90414</b> | Seal Seat Remover                    | <b>90415</b> | Seal Remover & Installer               |
| <b>90454</b> | Clutch Plate Remover (Coarse Thread) | <b>90458</b> | Clutch Plate Installer (Coarse Thread) |
| <b>90460</b> | O-Ring Installation Guide            | <b>90462</b> | Seal Seat Installer                    |
| <b>90484</b> | Seal Protector                       | <b>90486</b> | Ceramic Seal Installer                 |
| <b>90499</b> | Universal Clutch Holding Tool        | <b>91195</b> | Clutch Plate Removal Arbor             |



## 91270 SPECIAL GM DA6 SEAL SET

For carbon type seals used with tools from Set 91269.

Contains:

- |              |  |
|--------------|--|
| <b>91208</b> | Seal Remover & Installer               |
| <b>91211</b> | Shaft Protector                        |
| <b>91212</b> | Clutch Plate Remover (Metric Thread)   |
| <b>91213</b> | Clutch Plate Installer (Metric Thread) |
| <b>91214</b> | O-Ring & Snap-Ring Installer           |
| <b>91215</b> | O-Ring Installation Guide              |



## 91271 FORD FS6, CHRYSLER C171, NIPPONDENSO 6P 148A, TECUMSEH HR-980 SEAL SET

All specialized tools needed when replacing seals on the above compressors. Used with tools from Set 9126. Contains:

- |              |                           |
|--------------|---------------------------|
| <b>91052</b> | Clutch Plate Installer    |
| <b>91122</b> | Clutch Plate Remover      |
| <b>91060</b> | Seal Seat Remover         |
| <b>91202</b> | O-Ring Installation Guide |
| <b>91061</b> | Seal Seat Installer       |

## 91273 SANDEN 507/508/510 SEAL SET

All specialized tools needed when replacing seals on Sanden

Model 507, 508 and 510 compressors. Used with tools from

Set 91269. Contains:

- |              |                             |
|--------------|-----------------------------|
| <b>90902</b> | Clutch End Plate Puller     |
| <b>90906</b> | Seal Remover & Installer    |
| <b>90907</b> | Seal Protector Sleeve       |
| <b>90910</b> | Clutch Face Plate Installer |

## 91002 GM & FORD ORIFICE TUBE REMOVER/INSTALLER

Used on all GM (CCOT) and Ford (FOTCC) systems with evaporator inlet orifice tube.



## 91008 FORD (FOTCC) REMOVER/INSTALLER

Used for Ford systems produced after 1980.



## 91009 GM (CCOT) & FORD (FOTCC) SCREEN EXTRACTOR

Used with 91002 and 91008



## 91010 FORD AEROSTAR EXPANSION TUBE REMOVER/INSTALLER

Special design for condenser mounted tube.



**Mastercool®**  
"World Class Quality"

**POPULAR**



## 91000-A DELUXE CLUTCH HUB PULLER/INSTALLER KIT

Kit contains a complete offering of A/C compressor clutch hub pullers and installers for GM, Ford, Chrysler and Imports. Includes a compressor identification chart and comes in a custom molded case.



## 90499 UNIVERSAL CLUTCH HOLDING TOOL



## 92329 TOYOTA A/C DISCONNECT TOOL

The new Toyota spring lock A/C hose couplings require this special disconnect tool. Simply insert the end of the tool into the coupling to disengage the hose.



## 91320 NIPPONDENSO 10 PA17 SEAL SET

Includes all tools necessary to replace seals on Nippondenso. Used with tools from Set 91269. Contains:

- 91317 Shaft Seal Remover
- 91318 Shaft Seal Installer
- 91319 Shaft Protector
- 91329 Internal Snap-Ring Remover
- 91352 Plastic Box



## 92311 DELUXE ORIFICE TUBE SERVICE KIT

This 5 piece universal kit will remove and install any style orifice tube. Comes in custom molded box.















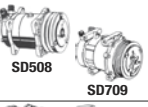
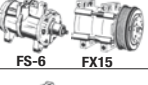

## 91332 FORD FX-15/FS-10 SERVICE SEAL SET

Includes all special tools needed to replace the seals on FX-15/FS-10 compressor. Contains:

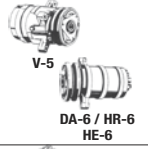
- 91326 Shaft Seal Remover
- 91327 Shaft Seal Installer
- 91328 Shaft Protector (16 Spline)
- 91329 Internal Snap-Ring Remover
- 91352 Plastic Box

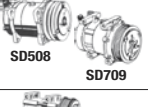
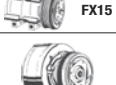

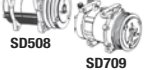
VEHICLE	COMPRESSOR MFG.	COMPRESSOR MODEL NUMBER	CLUTCH HUB		CLUTCH PULLEY		CLUTCH COIL		SHAFT SEAL		CLUTCH BEARING		Image
			Remover	Installer	Remover	Installer	Remover	Installer	Remover	Installer	Remover	Installer	
<b>Acura / Honda</b>	Nippondenso	6P Series 69127 10913 / 15	91011	91052	90450 91012	91059			91060 90499	91061	91059 91065	91059	 10P15
<b>Audi</b>	Delphi / Harrison	Harrison / GM A-6	90454	90458	90450 90455	91059			90414 90415 90499 90462	90414 90415 90486 90486	90350 90460 90412	90349	 (A-6)
	Zexel (Diesel Kiki)	DGW	91045		90917 90450	90910			91138 90499	91138	90443	91059	 Diesel Kiki
<b>Audi / VW</b>	Nippondenso	10PA-17 / 10P15	91011	91052	90450 91012	91059			91319 91317	91318 91319	91059 91065	91059	 10P15 10P17
	Sanden	TRS90 / 105	90902	90910	90926 90917	91059			90914	90414 90415	90443 90906	91059	 SD508
SD507 / 508 / 510 / 708 709 / 7H15 Lip Seal		90902	90910	90450	91059			90412	90908				
<b>BMW</b>	Nippondenso	10PA-17 / 10P15	91011	91052	90450 91012	91059			91319 91317	91318 91319	91059 91065	91059	 10P15 10P17
<b>Chrysler / Dodge</b>	Nippondenso	6C17	91303 91304		90450 91012	91059			91302 91302	91301 91065	91059	91059	
	Sanden	Sanden TRS90 / 105	90902	90910	90902 90917	91059			90914 90415	90414 90906	90443	91059	 SD508 SD709
SD507 / 508 / 510 / 708 709 / 7H15 Lip Seal		90902	90910	90450	91059			90412	90908	90443	91059		
<b>Ford / Lincoln</b>	Ford	FS-6	91122	91052	91012	91059	90450	91331	90499		91327	91065	 FS-6 FX15
		FS-10 (R134a) / FX-15	91122	91052	90450 91012	91059	91330	91331	91326 91328		91327	91065	
	Nippondenso	6P148	91011	91052	90450 91012	91059			91060 90499	91061	91059 91065	91059	 10P15
10PA-17 / 10P15		91011	91052	90450 91012	91059			91319 91317	91318 91319	91059 91065	91059		
<b>General Motors</b>	Delphi / Harrison	Harrison / GM A-6	90454	90458	90450 90455	91059			90414 90415 90486 90499 90462	90414 90415 90412 90486	90460	90349	 (A-6)
		R-4 Concave Shaft Tip	90454	90458	90346	90349	90346 90450	90292	90414 90415	90414 90415			 R-4
		Pointed Shaft Tip	91196	90458	90347	90349	90910	90292	90412 90499	90460 90484			
		V-5 & V-7 DA6 HR6 / HR6HE	91212	91213	90450 90453	91059	90450 90455 90291	90292	90486 91208 90412 90499 91170 90499	90486 91208 91214 90183 91211 91270	90350	90349	 V-5 DA-6 / HR-6 HE-6
<b>Honda</b>	Sanden	10PA-17 / 10P15	91011	91052	90450 91012	91059			91319 91317	91318 91319	91059 91065	91059	 10P15
<b>Hyundai</b>	Zexel (Diesel Kiki)	DKS15-BH			90450				90499				
	Sanden	Sanden TRS90 / 105	90902	90910	90926 90917	91059			90414 90415	90414 90906	90443	91059	 SD508 SD709
		SD507 / 508 / 510 / 708 709 / 7H15 Lip Seal	90902	90910	90450	91059			90412	90908	90443	91059	
Ford	FX15 / 10PA / 10P15	91011	91052	90450 91012	91059			91319 91317	91318 91319	91059 91065	91059	 FX15	
<b>Isuzu</b>	Delphi / Harrison	R-4 Concave	90454	90458	90346	90349	90346 90450	90292	90414 90415	90414 90415	90350	90349	 R-4
		Pointed Shaft Tip	91196	90458	90347	90349	90910	90292	90412 90499	90460 90484	90350	90349	
	Zexel (Diesel Kiki)	DKS 13/14/17 DGW / DKS15-BH			90450				90499				 Diesel Kiki
<b>Jaguar</b>	Sanden	SD5 & 7 Series Sanden TRS90 / 105	90902	90910	90926	91059			90914 90906	90414	90443	91059	 SD508 SD709
		SD507 / 508 / 510 / 708 709 / 7H15 Lip Seal	90902	90910	90917 90450	91059			90415 90412	90908	90443	91059	



# COMPRESSOR TOOL CHART

VEHICLE	COMPRESSOR MFG.	COMPRESSOR MODEL NUMBER	CLUTCH HUB		CLUTCH PULLEY		CLUTCH COIL		SHAFT SEAL		CLUTCH BEARING		Image
			Remover	Installer	Remover	Installer	Remover	Installer	Remover	Installer	Remover	Installer	
Jeep / Chrysler	Sanden	SD5 & 7 Series Sanden TRS90 / 105	90902	90910	90926	91059			90914	90414 90906	90443	91059	
		SD507 / 508 / 510 / 708 709 / 7H15 Lip Seal	90902	90910	90917 90450	91059			90415 90412	90908	90443	91059	
Mazda	Nippondenso	10PA-17 / 10P15	91011	91052	90450 91012	91059			91319 91317	91318 91319	91059 91065	91059	
	Ford	FS-6 FS-10 (R134a) / FX-15	91122	91052	91012	91059	90450 91330	91331	91326 91328	91327			
	Sanden	SD5 & SD7 Sanden TRS90 / 105	90902	90910	90926	91059			90914	90414 90906	90443	91059	
		SD507 / 508 / 510 / 708 709 / 7H15 Lip Seal	90902	90910	90917 90450	91059			90415 90412	90908	90443	91059	
Mercedes Benz	Delphi / Harrison	A-6 & R-4	90454	90458	90450 90455	91059			90414 90415 90486 90499	90414 90415 90412 90486 90462	90460	90349	
	Nippondenso	10P15 / 1710PA-17	91011	91052	90450 91012	91059			91319 91317	91318 91319	91059 91065	91059	
Mitsubishi	Mitsubishi	CH Series FX105	92260 90902		90917 90450	90910			91338 90499	91138	90443	91059	
	Nippondenso	10P15-17 / 10PA-17	91011	91052	90450 91012	91059			91319 91317	91318 91319	91059 91065	91059	
Nissan / Infiniti	Zexel (Diesel Kiki)	DKV-14C CH Series	92260 90902		90917 90450	90910			91328 90499	91138	90443	91059	
		DKS-16H CH Series	92260 90902		90917 90450	90910			91328 90499	91138	90443	91059	
Nissan	Ford	FS-10 FS-6 FS-10 (R134a) FX-15	91122	91052	91012 90450	91059	90450 91330	91331	90499 91328	91327	91065		
	Hitachi	MJS170 6P Series	91011	91052	90450 91012	91059			91060 90499	91061	91059 91065	91059	
Porsche	Nippondenso	10P 10PA-17 10P15	91011	91052	90450 91012	91059			91319 91317	91318 91319	91059 91065	91059	
	Hitachi	10P	91011	91052	90450 91012	91059			91060 90499	91061	91059 91065	91059	
	Sanden	SD5 Sanden TR594105 SD507 / 508 / 510 / 708 709 / 7H15 Lip Seal	90902	90910	90926	91059			90914	90414 90906	90443	91059	
Saab	*Sanden Seiko Seiki	SD5 Series / SS170 Sanden TR59105	90902	90910	90926	91059			90914	90414 90906	90443	91059	
		SD507 / 508 / 510 / 708 709 / 7H15 Lip Seal	90902	90910	90917 90450	91059			90415 90412	90908	90443	91059	
Saturn	Zexel (Diesel Kiki)	DKV CH Series	92260 90902		90917 90450	90910			91328 90499	91138	90443	91059	
Subaru	Zexel (Diesel Kiki)	*92 Model / 93 CH Series	92260 90902		90917 90450	90910			91328 90499	91138	90443	91059	
Suzuki	Nippondenso	10P8 10PA-17 10P15	91011	91052	90450 91012	91059			91319 91317	91318 91319	91059 91065	91059	
Toyota / Lexus	Nippondenso	10P13 / 15 / 17 10PA-17 10P15	91011	91052	90450 91012	91059			91319 91317	91318 91319	91059 91065	91059	
MB/Porsche/VW	York	206 / 209 / 210 York / Tecumseh	90440								90443	91059	
Volvo	Zexel (Diesel Kiki)	DKS-15 CH Series	92260 90902		90917 90450	90910			91328 90499	91138	90443	91059	
	Sanden	SD508 / 510 / 709 Sanden TR594105 SD507 / 508 / 510 / 708 709 / 7H15 Lip Seal	90902	90910	90926	91059			90914	90414 90906	90443	91059	
Volvo / Jaguar	Delphi / Harrison	A-6 & R-4 CH Series	90454	90458	90450 90455	91059			90414 90415 90486 90499	90414 90415 90412 90486 90462	90460	90349	



ITEM #	PAGE	ITEM #	PAGE	ITEM #	PAGE	ITEM #	PAGE	ITEM #	PAGE	ITEM #	PAGE	ITEM #	PAGE
0332-002	14	45602	10	49264-60	10	53827	29	70069-A	39	71216	34, 36	80661	8
0377-001	13, 14, 16	45603	10	49264-72	10	55100	30	70071	39	71300	36	80772	8
0378-001	13, 16	45721	10	49265-36	10	55100-SEN	30	70072	39	71400	35	81113	8
0531-001	13, 16	45722	10	49265-60	10	55200	30	70073	39	71405	34, 35	81290	13, 16
0768-001	13, 16	45723	10	49265-72	10	55300	30	70074	39	71406	34, 35	81297	14
0769-001	13, 16	45961	10	52161	33	55310	30	70075	39	71415	34, 35	81379	14
1336-006	13	45962	10	52220	33	55400	30	70076	39	71416	34, 35	82010	13, 14
1336-008	13	45963	10	52223-A	33	55500	31	70077	39	71450	35	82010-10	11
1336-010	13	46336	10	52224-A	32	55500-220	31	70081	39	71450-PB	35	82031	18
1336-012	13	46360	10	52224-C	32	55500-SEN	31	70082	39	71475	34	82214	12
1336-016	13	46361	10	52225-A	32	55750	31	70085	39	71475-10M	34, 35	82214-E	12
1336-018	13	46362	10	52225-B	33	55750-220	31	70092	36	71475-110M	34, 35	82224	12
1336-110	13	46363	10	52226	33	58211	9	70092-M	36	71475-14M	34, 35	82224-E	12
1336-112	13	46364	10	52227	33	58212	9	70097	36	71475-16M	34, 35	82272	14
32636	8	46372	10	52331	33	58213	9	70097-M	36	71475-18M	34, 35	82274	14
32661	8	46396	10	52332	33	58214	9	70128	39	71475-4M	34, 35	82275	14
32772	8	46601	10	52333	33	58490	16	70134	39	71475-6M	34, 35	82332	14
33103	8	46602	10	52334	33	58531	16	70138	39	71475-8M	34, 35	82333	14
33636	8	46603	10	52335	33	58560	16	70192	36	71475-PB	34	82335	14
33661	8	46604	10	53000-300	26	60034-10	12	70192-M	36	71480	35	82336	13
33772	8	46721	10	53000-42	26	60134-10	12	70233	39	71500	37	82336-10	11
34215	9	46722	10	53000-70	26	62010	17	70237	39	71500-001A	37	82354	14
34216	9	46723	10	53000-PB	26	62011	17	70238	39	71500-001B	37	82357	14
35636	8	46724	10	53000-W	26	62012	17	71097-01	34, 35, 36	71500-001C	37	82358	14
35661	8	46961	10	53001	26	63010	17	71097-03	34, 35, 36	71500-10	37	82374	29
35772	8	46962	10	53010-AUT	26	63010-AUS	17	71097-04	34, 35, 36	71500-10SRB	37	82375	29
36636	8	46963	10	53012	28	64010	17	71097-05	34, 35, 36	71500-12	37	82495	11
36661	8	46964	10	53012-B	28	65010	17	71097-05	36	71500-12SRB	37	82633	14
36772	8	47336	10	53012-L	28	66010	17	71097-06	34, 35, 36	71500-6	37	82634	12, 14
37636	8	47360	10	53042	26	66011	17	71097-08	34, 35, 36	71500-6SRB	37	82634-M	12, 14
37661	8	47361	10	53100	27	66012	17	71097-13	34, 35, 36	71500-8	37	82635	12
37772	8	47362	10	53100-C	27	66434-R	12, 26	71097-14	34, 35, 36	71500-PB	37	82733	12
40336	10	47363	10	53123	29	66534-R	12	71097-15	34, 35, 36	71500-REPAIRKT	37	82734	12, 14
40360	10	47364	10	53123-A	29	66660	8	71097-16	34, 35, 36	71550	37	82735	12
40372	10	47372	10	53134	29	66661	8	71097-18	34, 35, 36	71550-001	37	82736	12
40396	10	47396	10	53223	29	67010	17	71098	34	71550-002	37	82738	12
41361	10	47482	26	53312	28	67011	17	71098-01	35	71550-003	37	82834	12, 26
41362	10	47482	26	53312-B	28	69000	23	71098-03	35	71550-PB	37	82836	12
41363	10	47601	10	53312-L	28	69100	23	71098-08	35	71685	39	82836-E	12
41601	10	47602	10	53314	28	69110	23	71098-13	35	71686-2	39	82934	12
41602	10	47603	10	53315	28	69134-A	26	71098-14	35	72029	38	82934-E	12
41603	10	47604	10	53322	29	69300	22	71098-15	35	72030	38	83102	7
41721	10	47721	10	53351	27	69360	22	71098-16	35	72034	38	83136	8
41722	10	47722	10	53451-110	27	69370	22	71098-18	35	72035	38	83161	8
41723	10	47723	10	53451-C-110	27	69500	24	71099-06	34	80011	15	83172	8
41961	10	47724	10	53500	27	69500-DR	22	71099-16	34	80013	15	83272	7
41962	10	47961	10	53500-C	27	69788-A	25	71099-TC	34	80021	38	83341	12, 13, 14
41963	10	47962	10	53512-UV	28	69788-FLTRPK	25	71100	36	80034	12, 13	83341-10	11
42010	13, 14	47963	10	53515	28	69789	25	71101	36	80034-1	13	83372	10
42010-10	11	47964	10	53515-B	28, 30, 31	69789-H	25	71124	34	80034-2	13	83436	8
42014	13, 14	48364	10	53517-UV	28	70027	38	71144	34	80103	8	83461	8
42014-10	11	48604	10	53518-UV	28	70028	39	71175	34	80121	38	83472	8
42016	13	48724	10	53580	27	70029	38	71197	34	80132-2	13	83634	7
45336	10	48964	10	53585	27	70030	38	71200-PB	35	80134	12, 13	83721	10
45360	10	49262-36	10	53609	29	70031	38	71201	34, 35, 36	80134-1	13	83722	10
45361	10	49262-60	10	53610	29	70033	36, 38	71201-001A-REPK	34	80136	8	83723	10
45362	10	49262-72	10	53625	29	70034	39	71204	34, 36	80161	8	83834	12
45363	10	49263-36	10	53809	29	70035	38	71205	34, 36	80172	8	83934	12
45372	10	49263-60	10	53810	29	70037	38	71206	34	80234	12, 14	84136	8
45396	10	49263-72	10	53825	29	70038	38	71214	34, 36	80296	14	84161	8
45601	10	49264-36	10	53826	29	70051	36	71215	34, 36	80636	8	84172	8



# INDEX

ITEM #	PAGE	ITEM #	PAGE	ITEM #	PAGE	ITEM #	PAGE	ITEM #	PAGE	ITEM #	PAGE	ITEM #	PAGE
84336	10	87350	7, 9	90332	14	90902	40, 41, 43, 44	91208	41, 43	92398	28	98364	10
84360	10	87500	7, 9	90333-R	11, 14	90903	40	91211	41, 43	92636	8	98370	12
84361	10	88136	7	90333-UV	11	90905	40	91212	41, 43	92661	8	98604	10
84362	10	88161	7	90335-R	11, 14	90906	40, 41, 43, 44	91213	41, 43	92699	29	98660	7
84363	10	88172	7	90336	13, 14	90907	40, 41	91214	41, 43	92708	29	98661	7
84364	10	88436	7	90336-10	11	90908	43, 44	91215	41	92709	29	98724	10
84365	10	88461	7	90337	11, 14	90910	40, 41, 43, 44	91253-EE	9	92710	29	98964	10
84372	10	88472	7	90338	14	90914	43, 44	91269	41	92711	29	99134-A	5
84396	10	89136	7	90340	14	90916	40	91270	41, 43	92712	29	99134A-UPDT-10	5
84601	10	89161	7	90341	13	90917	40, 43, 44	91271	41	92732	29	99860-A	5
84602	10	89172	7	90341	13, 14	90922	40	91273	41	92772	8	99872-A	5
84603	10	89636	7	90346	43	90923	40	91290	16	93000	15		
84604	10	89660	7	90347	43	90924	14	91292	40	93098	15		
84605	10	89661	7	90349	43, 44	90925	15	91295	40	93099	15		
84636	8	89772	7	90350	43	90926	40, 43, 44	91301	43	93100	15		
84661	8	90010-6	19	90354	14	90927	14	91303	43	93101	15		
84721	10	90018-6	19	90355	14	90934	15	91304	43	93103	8		
84722	10	90024-6	19	90356	14	90935	15	91311	40	93211	9		
84723	10	90032-6	19	90357	14	91000-A	42	91317	42, 43, 44	93211-R	9		
84724	10	90059-R	19	90358	14	91002	41	91318	42, 43, 44	93253-E	9		
84725	10	90060	18	90363	12	91008	41	91319	42, 43, 44	93254-E	26		
84772	8	90062-A	19	90364	12	91009	41	91320	42	93350	9		
84961	10	90065	18	90365	11	91010	41	91326	42, 43, 44	93500	9		
84962	10	90066-2V-110	19	90368	13, 14	91011	40, 43, 44	91327	42, 43, 44	93503-E	9		
84963	10	90066-A	19	90369	13, 14	91012	43, 44	91328	42, 43, 44	93553-E	9		
84964	10	90067	18	90373	14	91044	40, 43	91329	42	93636	8		
84965	10	90070-2V-110	19	90375	29	91045	40, 43	91330	43, 44	93661	8		
85103	7	90128-4	19	90376	16	91046-A	16	91331	43, 44	93772	8		
85113	7	90160-R	18	90377	16	91047	40	91332	42	95102-R-KIT	9		
85136	7	90165-R	18	90378	13	91048	16	91334	13	95103-A	6		
85161	7	90167-R	18	90381	40	91052	40, 41, 43, 44	91334-A	13	95161-A	6		
85172	7	90183	43	90383	40, 41	91058	40	91335	13	95172-A	6		
85200	13	90259	11	90385	40	91059	40, 43, 44	91336	13	95236-A	6		
85211	9	90260	44	90386	40	91060	40, 41, 43, 44	91337	13, 16	95261-A	6		
85211-R	9	90262	11	90389	11	91061	40, 41, 43, 44	91338	44	95272-A	6		
85212	9	90262-36	10	90390	40	91065	43, 44	91339	13	95336-A	6		
85212-R	9	90262-60	10	90396	40	91073	40	91352	42	95361-A	6		
85215	9	90262-72	10	90410	14	91074	40	91490	16	95372-A	6		
85216	9	90263	11	90412	40, 41, 43, 44	91075	40	91503-EE	9	95436-A	6		
85253-E	9	90263-36	10	90413	26	91076	40	91536-A	6	95461-A	6		
85350	9	90263-60	10	90414	40, 41, 43, 44	91077	40	91553-EE	9	95472-A	6		
85500	9	90263-72	10	90415	41, 43, 44	91084	14	91580	24	95636	8		
85510	15	90264	11	90430	11	91090	40	91580-A	24	95661	8		
85511	14	90264-36	10	90440	44	91091	40	91580-B	24	95772	8		
85525	15	90264-60	10	90443	40, 43, 44	91120	33	91581	24	96636	8		
85530	15	90264-72	10	90450	43, 44	91122	41, 43, 44	91585	24	96661	8		
85636	7	90265	11	90451	40	91134	40	91585-B	24	96772	8		
85661	7	90265-36	10	90453	43	91135	40	91586	24	97636	8		
85772	7	90265-60	10	90454	41, 43, 44	91136	40	91587	24	97661	8		
86103	6	90265-72	10	90455	43, 44	91137	40	91588	24	97772	8		
86350	9	90269	11	90457	40	91138	40, 43, 44	91680	24	98061	19		
86436	6	90274	14	90458	41, 43, 44	91139	40	91681	24	98061-C	19		
86461	6	90279	11	90460	41, 43, 44	91146	40	91685	24	98100	20		
86472	6	90289	11	90462	41, 43, 44	91170	43	91686	24	98210-A	21		
86500	9	90291	43	90484	41, 43	91171	40	91687	24	98211-A	21		
86536	6	90292	43	90486	41, 43, 44	91183	40	91688	24	98230	21		
86561	6	90296	14	90499	40, 41, 42, 43, 44	91195	41	92107	13	98250	20		
86572	6	90314	14	90633	14	91196	43	92260	44	98250-220	20		
86936	6	90328	11	90637	14	91200	18	92311	42	98251-E	9		
86961	6	90330	14	90638	14	91202	41	92329	42	98310	20		
86972	6	90331	14	90901	40	91207	13	92376	29	98315	20		









**Mastercool<sup>®</sup>**  
*"World Class Quality"*

One Aspen Drive Randolph, NJ 07869 USA  
Phone: (973) 252-9119 / Fax: (973) 252-2455

Europark Noord 14B  
9100 Sint Niklaas, Belgium  
Telefon: +32 (0) 3 777 28 48 / Telefax: +32 (0) 3 777 40 62

website: [www.mastercool.com](http://www.mastercool.com) / email: [customerservice@mastercool.com](mailto:customerservice@mastercool.com)