

Data sheet

# ACCSCS

## Fans speed control



ACCSCS are designed to regulate the speed of fans and pumps proportionally and continuously. They function as a simple voltage regulator whose command signal (PWM for single phase controllers and 0..10 V or 4..20 mA or PWM for three phase controllers) comes from an external regulating device.

It's possible to connect more than one motor in parallel provided that the maximum input regulating current is less than the controller nominal current.

### Features ACCSCS

#### Single phase model

- Power 230 V
- Input voltage 230 V AC -15 +10%, 50/60 Hz
- Output voltage 0...98% of supply line
- Command signal PWM
- RF filter inside

#### Three phase model

- Power 400 V
- Input voltage three phase 400 V AC -15 +10%, 50/60 Hz
- Output voltage 30...99% of supply line
- Command signal 0...10 V, 4..20 mA and PWM 5 / 10 V
- Aux output supply +10 V aux power (I<sub>max</sub> = 50 mA) for external potentiometer
- Output relay that commutate in case of phase loss or overtemperature

**General features**

FEATURES	DESCRIPTION
Power supply	400 V AC or 230 V AC
Metal housing	DIN rail mounting
Test	According to EN60730 this device provides a type 1 action, it is an incorporated controller suitable for assembly on a flat surface and for use in conditions of normal pollution.
Storage conditions	-20 °C...+70 °C
Index of protection	Plastic covering which is self-extinguishing: IP55 Metallic covering: IP20
EMC (Electro-Magnetic Compatibility)	The controller has a built-in suppression filter to meet all required CE directives. Danfoss controls are designed to be installed inside a machine or a standard electrical cabinet and is therefore considered a component. It is the installer's responsibility to observe the criteria of compatibility to guarantee compliance with the directives.
Wiring	All wiring should conform to local regulations and must be made by authorized personnel only. All connections wires must ensure efficient insulation also at temperatures exceeding 80 °C. Attach the controller to a non-painted plate with anti-corrosive treatment. If the length of the motor cable exceeds 5 m, use shielded cable. To avoid dispersion currents, both ends of the motor cable shield, the motor earth, and the controller earth must be connected to the same earth pole. If the control cable length exceeds 2 m, use shielded cable, connecting the shield only at the end of the controller. Ensure that the control 0 V is not connected to earth. If the power, motor and control cables exceed 10 m, make sure they are separated by at least 0.3 m to avoid creating a coupling effect. To protect the power line and the regulator, the installation technician must install extra-rapid fuses upstream of the power supply. If a differential circuit breaker is installed, it must be of the delayed action type.

**Technical data  
single phase**

<b>FEATURES</b>	<b>080G0215</b>
Power - 230 V AC	2 KVA
Current nom (Arms)	8 A
Input voltage	Single phase 230 V AC -15 +10%, 50/60 Hz
Output voltage	0...98% of supply line
Command signal	PWM
Protections	Class II at the input terminal block (4 KV) Surge protection
Operating temperature	-10 °C...+50 °C
Storage temperature	-20 °C...+70 °C
Protection degree	Metallic covering IP20
Dimensions (mm) - LxHxP	90x120x85

**Technical data  
three phase**

<b>FEATURES</b>	<b>080G0217</b>	<b>080G0218</b>	<b>080G0219</b>	<b>080G0220</b>
Power - 400 V AC	5.5 KVA	8 KVA	13 KVA	19 KVA
Current nom (Arms)	8 A	12 A	20 A	28 A
Input voltage	Three phase 400 V AC -15 +10%, 50/60 Hz			
Output voltage	30...99% of supply line			
Command signal	Signal 0...10 V, 4...20 mA, PWM 5/10 V and Modbus			
Analog output	+10 V (max load 50 mA)			
Digital output	Emergency relay 1 A-250 V AC / 3 A-30 V DC			
Protections	Class II at the input terminal block (4 KV) Class I as regards the accessible parts Phase lost, overheating (the regulator restores automatical)			
Operating temperature	-10 °C...+50 °C (-20 °C when the power is maintained)			
Max heat sink temperature	75 °C			
Storage temperature	-20 °C...+80 °C			
Protection degree	Self-extinguishing plastic covering IP55			
Dimensions (mm) - LxHxP	230x165x150	230x265x165	230x265x230	340x270x235

**MODbus address**

Example: Request by the MASTER to read the variable "output voltage" identified with address 0x0B: 01 03 00 0B 00 01.

Request by the MASTER to write on the variable "Modbus input command" identified with address 0x401: 01 06 04 01 00 01.

Caution: the regulation command via Modbus requires rewriting in its address within the time out (default 30 seconds) even if the value remains unchanged.

Over the time out, in absence of any other command signal, the regulator switch OFF the power outputs.

HEX address	Variable	Unit	Reading/ Writing	Min. value	Max. value	Description
0x00B	Voltage output	%	L	-	-	Indicates the output percentage voltage / speed
0x00D	Allarm	Num	L	-	-	0=no error 1=phase lost 3=over temperature 5=incorrect settings 6=timeout MDB
0x400	Stop regulation	Num	L/S	0	1	Write the value 1 to enable writing and disable the running place to 0 to re-enable the running
0x421	Regulator address	Num	L/S **)	1	247	Indicates the modbus address (slave) - default 0x01
0x422	Baudrate	Num	L/S **)	1	3	(=1 if 9600bps) (=2 if 19200) (=3 if 38400) - default =2
0x423	Stop Bit	Num	L/S **)	1	2	(=1 if 1 stop bit) (=2 if 2 stop bit) - default=1
0x424	Parity	Num	L/S **)	1	3	(=1 if no parity) (=2 if even parity) (=3 if odd parity) - default =1
0x425	Timeout	Sec	L/S *)	1	240	Indicates the time within which the master must renew his command regulation
0x401	Command by Modbus	%	L/S *)	0	100	Variable for command the regulation (0-100) by Modbus
0x402	Min. input	%	L/S *)	10	Max input	Voltage signal command / speed V1
0x403	Max input	%	L/S *)	Min. input	100	Voltage signal command / speed V2
0x404	Min. V1 voltage	%	L/S *)	Lim. min. motor	Max. V2 Voltage	Voltage / speed of IN.MIN. command signal point
0x405	Max. V2 voltage	%	L/S *)	Min. V1 voltage	Lim. max. motor	Voltage / speed of IN.MAX. command signal point
0x407	Reset	Num	L/S *)	1	3	(=2 to reset and load the controller's default values) (=3 to restart the regulator after changing the parameter / s when is required the reboot)
0x40A	Lim. Speed V1	%	L/S *)	Lim. min. motor	V2 limit	Voltage that replaces V1, when V1 LIMIT>V1
0x411	Kick start	Num	L/S *)	0	1	(=0 kick start enable) (=1 kick start able)
0x41E	Regulation profile	Num	L/S *)	1	2	(=1 linear profile) (=2 axial fans profile)

\*) writing possible only if the parameter "Adjustment Lock" is set to 1  
\*\*) necessary reebot after writing the changes

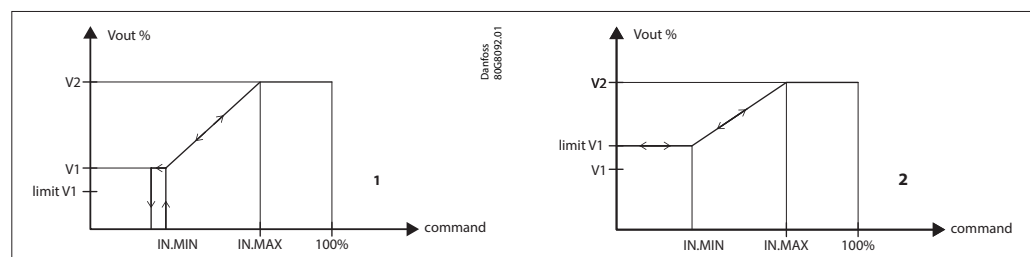

Connection diagram

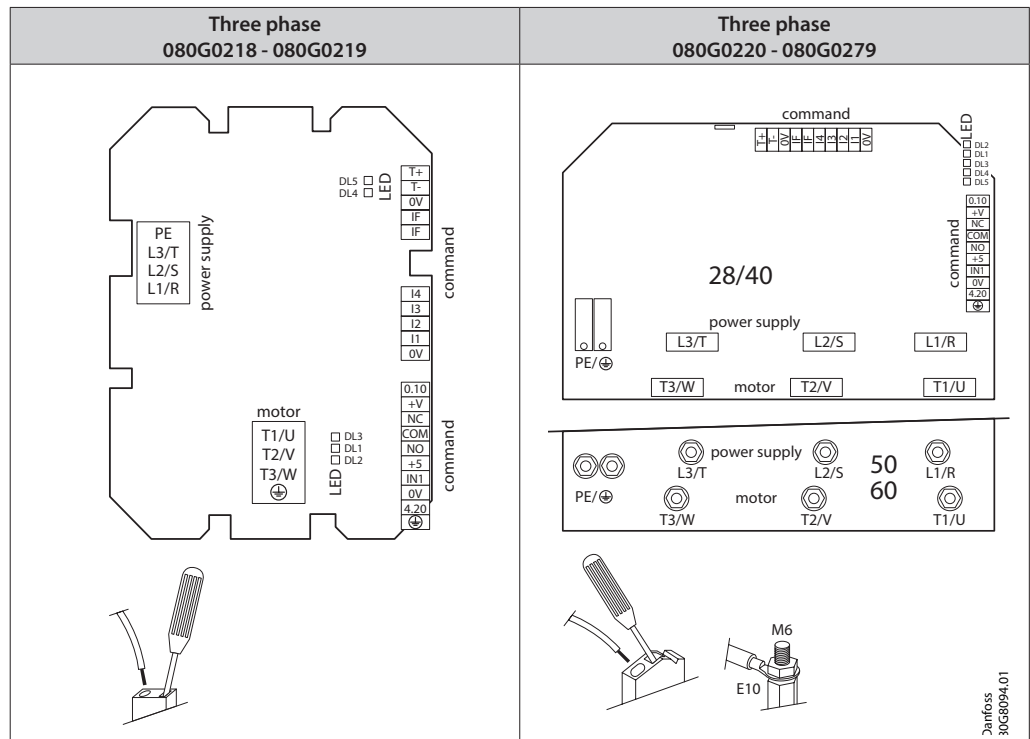
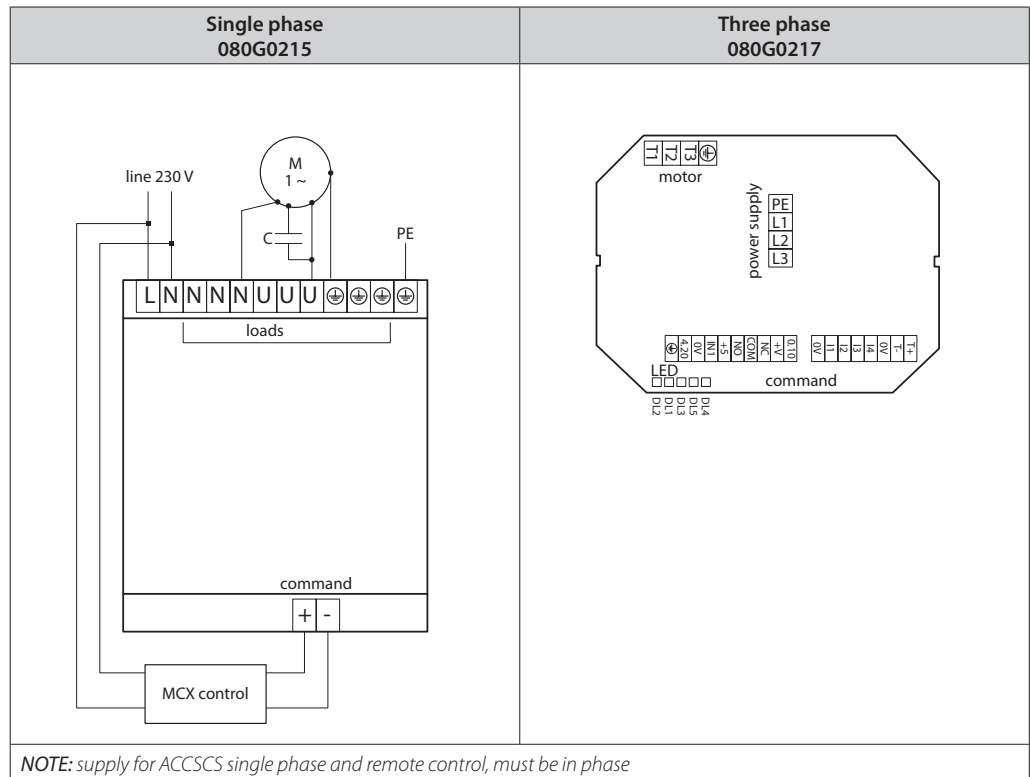

**Controls Terminal Board**

Name	Description	Application
T1 +	Serial RS485, Modbus RTU - slave	Serial connection line to a Master controlled device
T1 -	Serial RS485, Modbus RTU - slave	
0 V	Ground I/O	Ground I/O
IF	Pwm input 2..20 kHz (Ri = 500 Ω, 5..24 V)	Variable frequency command input IF (only on request)
IF		
0.10	Analog input, type 0..10 V (Ri = 40 kΩ)	0..10 V analog command input
+ V	Aux. supply output 12 V= (max 30 mA)	External potentiometer supply for manual command
NC	Relay 1 contact output normally closed	Programmable output. With standard setting for Defect, the relay is enabled (NO-COM eachother closed) and is disabled in emergency case
COM	Relay 1 common contact output (1A-250 V~ / 3 A-30 V=)	
NO	Relay 1 contact output norm. open	
+5 V	Output aux. supply 5 V= (max 15 mA)	/
IN 1	Analog input pwm (5..15 V, 100 Hz frequency)	PWM input command with variable average value
0 V	Ground I/O	Ground for analgical input
4.20	Analog input , type 4...20 mA (Ri = 100 Ω)	4..20 mA analog command input

**Dimensions**

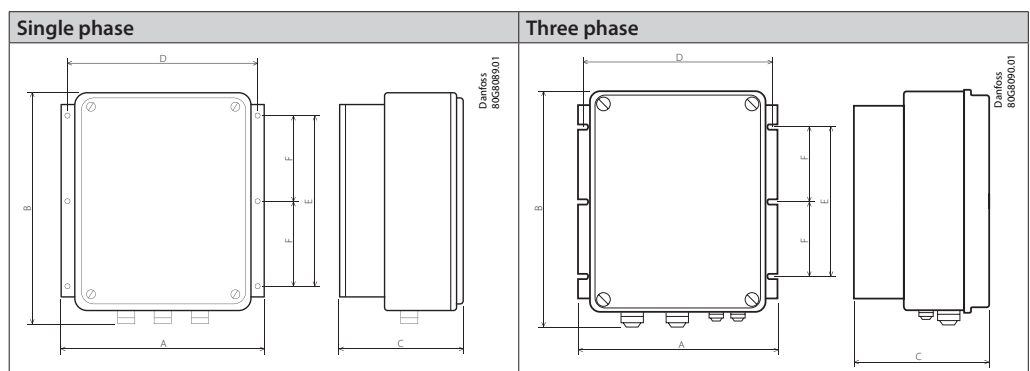

**Dimensions table**

CODE NO.	A	B	C	D	E	F	Weight
	[mm]	[mm]	[mm]	[mm]	[mm]	[mm]	[kg]
080G0215	90	120	85	-	-	-	0.35
080G0217	230	165	150	215	80	-	2.5
080G0218	230	265	165	215	170	-	4
080G0219	230	265	230	215	170	-	4.8
080G0220	340	270	235	322	165	-	7
080G0279	230	165	150	215	80	-	2.5

## Installation

### Mechanical installation

The ACCSCS regulator must be wall-mounted vertically, in order to guarantee adequate dispersion of heat in the area of air circulation and prevent obstructions to air flow in the dissipator zone. ACCSCS has IP55 grade protection, anyway protect it from corrosive liquids, gas, heat sources and position it preferably sheltered from the sun's rays. Make sure that it does not undergo vibrations.

### Electrical installation

All wiring should conform to local regulations and must be made by authorized personnel only. To protect the power line and the regulator, the installation technician must install extra-rapid semiconductor fuses upstream of the power supply adequate for the load and with a value of  $I^2 \times t$  less than the value given in the table below. If a differential circuit breaker is installed, it must be of the delayed action type. The data are related to operate at 400 V ~ 50 Hz. For 230 V voltage supply or models at 440 / 460 V all current data are the same. Max current refers to an environment temperature of 50 °C for a maximum time of 10 second every 5 minutes.

## Product part numbers

DESCRIPTION	CODE NO.
ACCSCS, SINGLE PHASE REG. 230VAC, 8A	080G0215
ACCSCS, THREE PHASE REG. 400VAC, 8A	080G0217
ACCSCS, THREE PHASE REG. 400VAC, 12A	080G0218
ACCSCS, THREE PHASE REG. 400VAC, 20A	080G0219
ACCSCS, THREE PHASE REG. 400VAC, 28A	080G0220
ACCSCS, THREE PHASE REG. 400VAC, 8A, I	080G0279